

Minicilindri Serie 16 - 24 - 25



Serie 16: \varnothing 8, 10, 12 mm
Serie 24: \varnothing 16, 20, 25 mm - magnetici
Serie 25: \varnothing 16, 20, 25 mm - magnetici, ammortizzati



- » Semplice e doppio effetto
- » CETOP RP52-P DIN/ISO 6432
- » Stelo e camicia in INOX
- » Testate in alluminio anodizzato

I minicilindri della Serie 16, 24 e 25 sono stati realizzati rispettando gli ingombri delle norme europee CETOP-RP52P DIN/ISO 6432. Le soluzioni tecniche adottate e la scelta adeguata dei materiali ci hanno permesso di predisporre una serie completa di minicilindri, versatile e molto affidabile.

Il particolare sistema di unione (bordatura) fra camicia e testata assicura la perfetta linearità di tutti i particolari. Poiché questi cilindri possono essere soggetti a cicli molto elevati, sono stati corredati di ammortizzatori di fine corsa (fissi) meccanici per ridurre la fatica dei materiali impiegati.

La Serie 24-25 è predisposta per il montaggio di sensori magnetici.

La Serie 25, inoltre, è stata realizzata con ammortizzatori pneumatici di fine corsa regolabili.

Gli accessori di corredo di questi cilindri ne consentono svariati fissaggi.

CARATTERISTICHE GENERALI

Tipo di costruzione	bordato
Funzionamento	a semplice e doppio effetto
Materiali	testate AL anodizzato - stelo e camicia inox - pistone AL - guarnizioni NBR - PU - altri vedi codifica
Fissaggio	ghiera - flangia - piedini - controcerniera
Corse min - max	Serie 16 \varnothing 8 ÷ \varnothing 10: 10 - 250 mm - Serie 16: \varnothing 12: 10 - 300 mm - Serie 24 e 25 \varnothing 16: 10 - 600 mm; \varnothing 20 - \varnothing 25: 10 - 1000 mm
Alesaggi	Serie 16: \varnothing 8, 10, 12 - Serie 24 e 25: \varnothing 16, 20, 25
Temperatura d'esercizio	0°C ÷ 80°C (con aria secca -20°C)
Pressione d'esercizio	1 ÷ 10 bar (doppio effetto); 2 ÷ 10 bar (semplice effetto)
Fluido	aria filtrata, senza lubrificazione. Nel caso si utilizzasse aria lubrificata, si consiglia olio ISOVG32 e di non interrompere mai la lubrificazione.
Velocità	10 ÷ 1000 mm/sec (senza carico)

TABELLA CORSE STANDARD PER MINICILINDRI

■ = Doppio effetto
 ✕ = Semplice effetto

CORSE STANDARD															
Serie	∅	10	25	40	50	80	100	125	160	200	250	300	320	400	500
16	8	■ ✕	■ ✕	■ ✕	■ ✕	■	■	■	■	■					
16	10	■ ✕	■ ✕	■ ✕	■ ✕	■	■	■	■	■					
16	12	■ ✕	■ ✕	■ ✕	■ ✕	■	■	■	■	■					
24	16	■ ✕	■ ✕	■ ✕	■ ✕	■	■	■	■	■	■	■	■	■	■
24	20	■ ✕	■ ✕	■ ✕	■ ✕	■	■	■	■	■	■	■	■	■	■
24	25	■ ✕	■ ✕	■ ✕	■ ✕	■	■	■	■	■	■	■	■	■	■
25	16	■	■	■	■	■	■	■	■	■	■	■	■	■	■
25	20	■	■	■	■	■	■	■	■	■	■	■	■	■	■
25	25	■	■	■	■	■	■	■	■	■	■	■	■	■	■

ESEMPIO DI CODIFICA

24	N	2	A	16	A	100	
24	SERIE 16 = non magnetico 24 = magnetico 25 = magnetico, ammortizzato, regolabile						
N	VERSIONE N = standard						
2	FUNZIONAMENTO 1 = semplice effetto, molla anteriore, non ammortizzato 2 = doppio effetto 3 = doppio effetto, stelo passante 7 = semplice effetto, stelo passante			SIMBOLI PNEUMATICI CS02 (s. 16) - CS06 (s. 24) CD01 (s. 16) - CD08 (s. 24) - CD09 (s. 25) CD05 (s. 16) - CD12 (s. 24) - CD13 (s. 25) CS04 (s. 16) - CS10 (s. 24)			
A	CARATTERISTICHE MATERIALI A = stelo INOX rullato AISI 303 - camicia INOX AISI 304 - testate AL anodizzato						
16	ALESAGGIO 08 = 8 mm - 10 = 10 mm - 12 = 12 mm - 16 = 16 mm - 20 = 20 mm - 25 = 25 mm						
A	TIPO COSTRUTTIVO A = ghiera V + dado stelo U RL = cilindro con bloccastelo ∅20 - ∅25.						
100	CORSA (vedi tabella)						
	= standard V = guarnizione stelo FKM W = tutte le guarnizioni in FKM, +130°C (solo per serie 25)						

SIMBOLI PNEUMATICI

I simboli pneumatici indicati nell'ESEMPIO DI CODIFICA sono riportati di seguito.

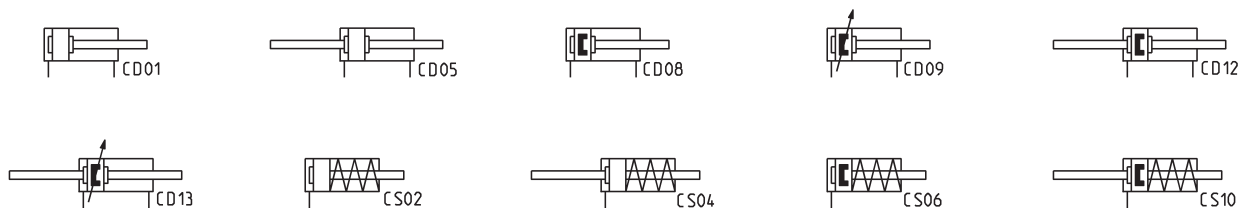

ACCESSORI MINI CILINDRI SERIE 16 - 24 - 25



Ancoraggio a piedino
Mod. B



Ancoraggio a flangia
Mod. E



Ancoraggio a
controcerniera Mod. I

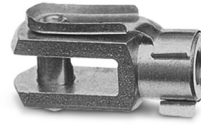

Forcella Mod. G



Snodo sferico Mod. GA



Snodo sferico maschio
Mod. GY



Dado stelo Mod. U



Ghiera Mod. V



Snodo autoallineante
Mod. GK



Giunto compensatore
Mod. GKF



Tutti gli accessori sono forniti separatamente al cilindro, ad eccezione del dado stelo Mod. U e della ghiera Mod. V

Minicilindri Serie 16 - 24 - 25

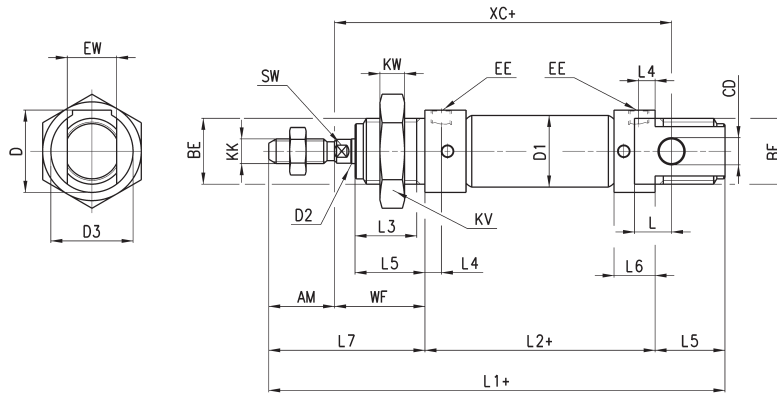

+ = sommare la corsa

INGOMBRI																									
Serie	∅	EW	KW	BE	KK	CD	D1	EE	∅D2	L1+	XC+	L2+	AM	L3	L4	L5	L	WF	L6	L7	KV	SW	D	D3	corsa di ammortizzo anteriore/posteriore
16	8	8	7	M12x1,25	M4x0,7	4	9,3	M5	4	86	64	46	12	10	4,5	12	6	16	9	28	19	-	15	15	- / -
16	10	8	7	M12x1,25	M4x0,7	4	11,3	M5	4	86	64	46	12	10	4,5	12	6	16	9	28	19	-	15	15	- / -
16	12	12	8	M16x1,5	M6x1	6	13,3	M5	6	105	75	50	16	15	4,5	17	9	22	9	38	24	5	20,5	20	- / -
24-25	16	12	8	M16x1,5	M6x1	6	17,3	M5	6	111	82	56	16	15	5,5	17	9	22	10	38	24	5	20,5	20	10 / 10
24-25	20	16	10	M22x1,5	M8x1,25	8	21,3	G1/8	8	132	95	68	20	18	8	20	12	24	16	44	32	7	27	27	13 / 15
24-25	25	16	10	M22x1,5	M10x1,25	8	26,5	G1/8	10	141,5	104	69,5	22	20	8	22	12	28	16	50	32	9	27	27	16 / 14

Minicilindri Serie 16 - 24 - 25 con stelo passante

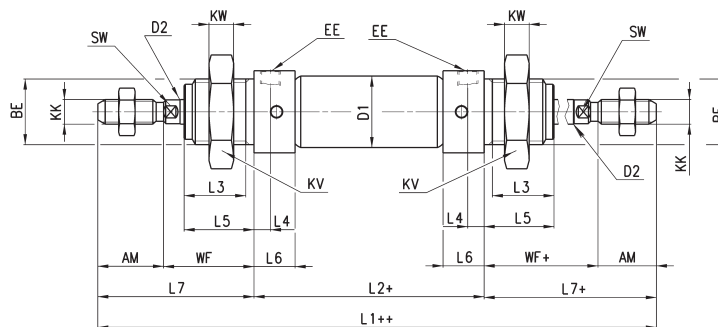

+ = sommare la corsa
 ++ = sommare 2 volte la corsa

INGOMBRI																			
Serie	∅	KW	BE	KK	∅D1	EE	∅D2	L1++	L2+	AM	L3	L4	L5	WF+	L6	L7+	KV	SW	corsa di ammortizzo anteriore/posteriore
16	8	7	M12x1,25	M4x0,7	9,3	M5	4	102	46	12	10	4,5	12	16	9	28	19	-	- / -
16	10	7	M12x1,25	M4x0,7	11,3	M5	4	102	46	12	10	4,5	12	16	9	28	19	-	- / -
16	12	8	M16x1,5	M6x1	13,3	M5	6	126	50	16	15	4,5	17	22	9	38	24	5	- / -
24-25	16	8	M16x1,5	M6x1	17,3	M5	6	132	56	16	15	5,5	17	22	10	38	24	5	10 / 10
24-25	20	10	M22x1,5	M8x1,25	21,3	G1/8	8	156	68	20	18	8	20	24	16	44	32	7	13 / 15
24-25	25	10	M22x1,5	M10x1,25	26,5	G1/8	10	169,5	69,5	22	20	8	22	28	16	50	32	9	16 / 14

Minicilindri Serie 24 - 25 con bloccastelo (Mod. RLC)



+ = sommare la corsa

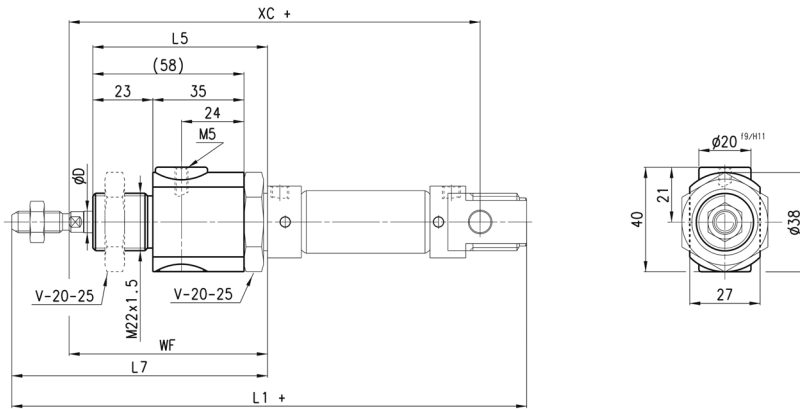

INGOMBRI								
Serie	ϕ	${}^{67}D$	WF	L5	L7	XC+	L1+	F (N)
24-25	20	8	74	70	94	145	182	300
24-25	25	10	76	70	98	152	189,5	400

Ancoraggio a piedini Mod. B



Materiale piedini e ghiera: acciaio zincato.

La fornitura comprende:
N° 2 piedini
N° 1 ghiera mod. V

+ = sommare la corsa

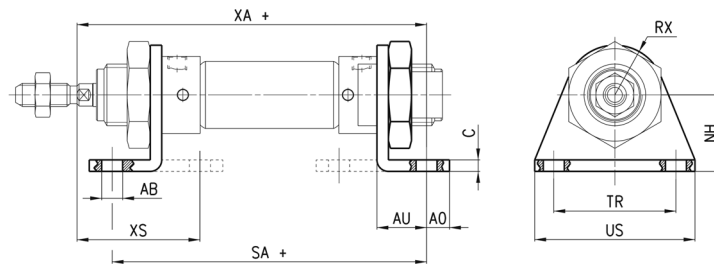

INGOMBRI												
Mod.	∅	∅AB	XS	XA+	SA+	AO	AU	C	RX	TR	US	NH
B-8-10	8-10	4,5	24	72,5	67	4,5	10,5	2,5	10	25	35	16
B-12-16	12	5,5	32	82,5	76	6	13	3	13	32	42	20
B-12-16	16	5,5	32	91	82	6	13	3	13	32	42	20
B-20-25	20	6,6	36	108	100	8	16	4	20	40	54	25
B-20-25	25	6,6	40	113,5	101,5	8	16	4	20	40	54	25

Ancoraggio a flangia Mod. E



Materiale: acciaio zincato

+ = sommare la corsa

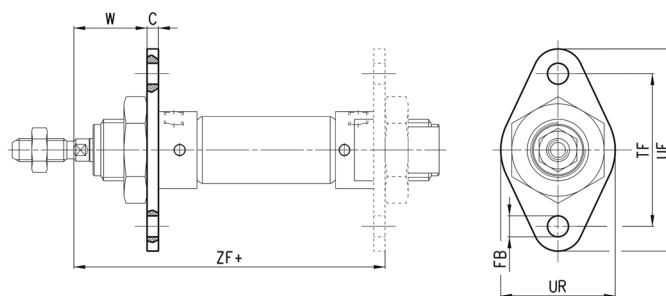

INGOMBRI								
Mod.	∅	W	C	ZF+	FB	UF	TF	UR
E-8-10	8-10	13,5	2,5	64,5	4,5	40	30	25
E-12-16	12	19	3	75	5,5	53	40	30
E-12-16	16	19	3	81	5,5	53	40	30
E-20-25	20	20	4	96	6,6	66	50	40
E-20-25	25	24	4	101,5	6,6	66	50	40

Ancoraggio a controcerniera Mod. I



La fornitura comprende:
N° 1 cerniera femmina in acciaio zincato
N° 1 spinotto in acciaio INOX
N° 2 Seeger in acciaio

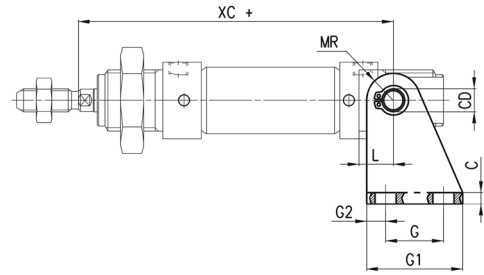
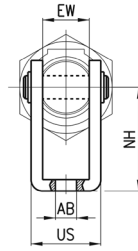

+ = sommare la corsa

INGOMBRI													
Mod.	∅	EW	∅AB	US	NH	XC+	MR	L	G2	G	G1	CD	C
I-8-10	8-10	8	4,5	13,1	24	64	5	6	3,5	12,5	20	4	2,5
I-12-16	12	12	5,5	18,1	27	75	7	9	5	15	25	6	3
I-12-16	16	12	5,5	18,1	27	82	7	9	5	15	25	6	3
I-20-25	20	16	6,6	24,1	30	95	10	12	6	20	32	8	4
I-20-25	25	16	6,6	24,1	30	104	10	12	6	20	32	8	4

Forcella Mod. G

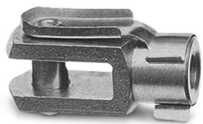

ISO 8140
Materiale: acciaio zincato

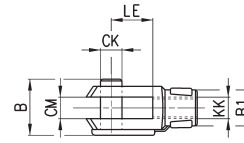
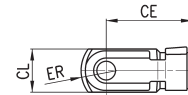

INGOMBRI										
Mod.	∅	CL	ER	CE	B	CM	∅CK	LE	KK	∅B1
G-8-10	8-10	8	5	16	11	4	4	8	M4x0,7	8
G-12-16	12-16	12	7	24	16	6	6	12	M6x1	10
G-20	20	16	10	32	22	8	8	16	M8x1,25	14
G-25-32	25	20	12	40	26	10	10	20	M10x1,25	18

Snodo sferico Mod. GA



ISO 8139
Materiale: acciaio zincato

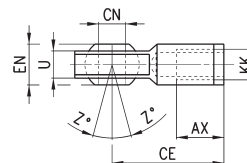
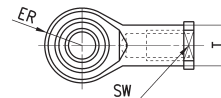

INGOMBRI											
Mod.	∅	∅CN ^(H7)	U	EN	ER	AX	CE	KK	∅T	Z	SW
GA-8-10	8-10	5	6	8	9	10	27	M4x0.7	9	6.5°	9
GA-12-16	12-16	6	7	9	10	12	30	M6X1	10	6.5°	11
GA-20	20	8	9	12	12	16	36	M8X1.25	12.5	6.5°	14
GA-32	25	10	10.5	14	14	20	43	M10X1.25	15	6.5°	17

Snodo sferico maschio Mod. GY



ISO 8139
Materiale: zama e acciaio zincato

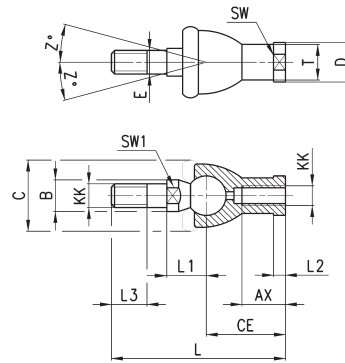

INGOMBRI																
Mod.	∅	Z	E	SW	$\varnothing T$	$\varnothing D$	$\varnothing C$	$\varnothing B$	KK	L3	SW1	L1	L	CE	AX	L2
GY-12-16	12-16	15	6	11	10	13	20	10	M6X1	11	8	12,2	55	28	15	5
GY-20	20	15	8	14	12,5	16	24	12	M8X1,25	12	10	16	65	32	16	5
GY-32	25	15	10	17	15	19	28	14	M10X1,25	15	11	19,5	74	35	18	6,5

Dado stelo Mod. U



UNI EN ISO 4035
Materiale: acciaio zincato

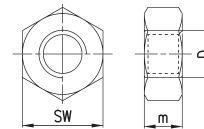

INGOMBRI				
Mod.	∅	SW	m	D
U-8-10	8-10	7	3	M4X0,7
U-12-16	12-16	10	4	M6X1
U-20	20	13	5	M8X1,25
U-25-32	25	17	6	M10X1,25

Ghiera Mod. V



UNI EN ISO 4035
V-8-10 / V-20-25 non a norma
Materiale: acciaio zincato

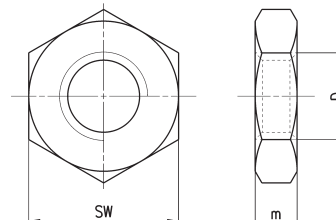

INGOMBRI				
Mod.	∅	D	m	SW
V-8-10	8-10	M12X1,25	7	19
V-12-16	12-16	M16X1,5	8	24
V-20-25	20-25	M22X1,5	10	32

Snodo autoallineante Mod. GK

Materiale: acciaio zincato

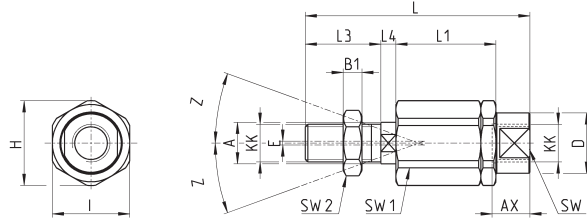

INGOMBRI																	
Mod.	∅	H	I	Z	₆ A	KK	E	L	L3	L4	L1	B1	SW2	SW1	AX	SW	₆ D
GK-12-16	12-16	14.5	13	3	6	M6x1	1	35	11	2.5	17.5	4	10	5	12.5	7	8.5
GK-20	20	19	17	4	8	M8x1,25	2	57	21	5	26	4	13	7	16	11	12.5
GK-25-32	25-32	32	30	4	14	M10x1,25	2	71.5	20	7.5	35	5	17	12	22	19	22

Giunto compensatore Mod. GKF

Materiale: acciaio zincato

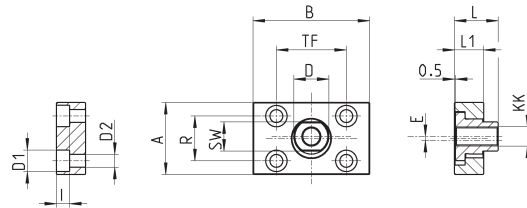
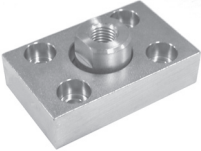

INGOMBRI														
Mod.	∅	∅ D1	I	∅ D2	A	R	SW	B	TF	∅ D	E	L	L1	KK
GKF-20	20	5,5	-	-	30	20	13	35	25	14	1,5	22,5	10	M8x1,25
GKF-25-32	25	11	6,8	6,6	37	23	15	60	36	18	2	22,5	15	M10x1,25