

# Cilindri Compatti magnetici Serie 32

Semplice e doppio effetto, antirotazione  
 Ø 20, 25, 32, 40, 50, 63, 80, 100 mm

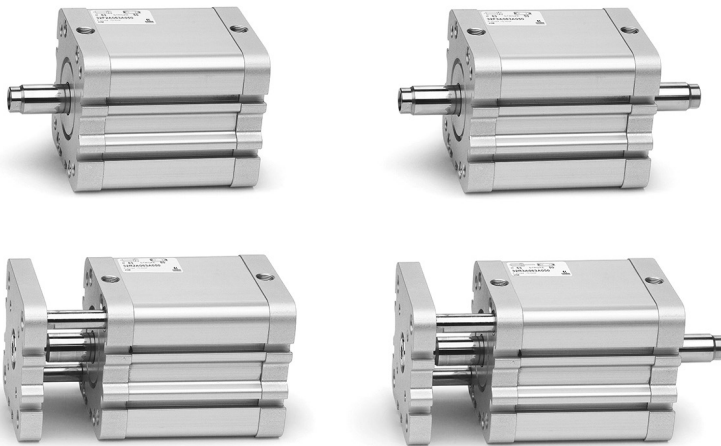

CILINDRI SERIE 32



- » Conformi alla normativa ISO 21287
- » Design Compatto
- » Ampia gamma di modelli disponibili in vari diametri

I cilindri Serie 32, grazie alla loro estrema compattezza, sono adatti per l'installazione in spazi contenuti.  
 Conformi alla normativa ISO 21287, consentono un grande vantaggio nell'uso di fissaggi identici ad altre serie di cilindri DIN/ISO 6431 / VDMA 24562 (Serie 60/61).

## CARATTERISTICHE GENERALI

<b>Tipo di costruzione</b>	a profilo compatto
<b>Funzionamento</b>	semplice e doppio effetto magnetico
<b>Materiali</b>	Testate e profilo in alluminio anodizzato - stelo inox AISI 303 rullato pistone in alluminio anodizzato - guarnizione stelo - or testata e guarnizione pistone in pu alte temperature guarnizione stelo - or testata e pistone in FKM (140°)
<b>Fissaggio</b>	con fori filettati sulle testate flangia - piedini - cerniere
<b>Corse min. e max. (1)</b>	Serie 32F,32M,32R Ø20-25=5-300mm Serie 32F,32M,32R Ø32-40-50-63=5-400mm Serie 32F,32M,32R Ø80-100=5-500mm
<b>Temperatura d'esercizio</b>	0°C ÷ 80°C (con aria secca -20°C)
<b>Pressione d'esercizio</b>	1 ÷ 10 bar (doppio effetto) 2 ÷ 10 bar (semplice effetto)
<b>Fluido</b>	Aria filtrata senza lubrificazione nel caso si utilizzasse aria lubrificata, si consiglia olio ISOVG32 e di non interrompere mai la lubrificazione.
<b>Velocità d'esercizio</b>	10 ÷ 1000 mm\sec (senza carico)

(1) = la corsa minima per l'utilizzo dei sensori è di 10 mm.

## TABELLA CORSE STANDARD PER CILINDRI SERIE 32

✕ = Antirotazione;    ● = Doppio effetto maschio/femmina;  
 ■ = Semplice effetto molla ant./post. maschio/femmina.

CORSE STANDARD										
Ø	5	10	15	20	25	30	40	50	60	80
20	✕ ● ■	✕ ● ■	✕ ● ■	✕ ● ■	✕ ● ■	✕ ●	✕ ●	✕ ●		
25	✕ ● ■	✕ ● ■	✕ ● ■	✕ ● ■	✕ ● ■	✕ ●	✕ ●	✕ ●		
32	✕ ● ■	✕ ● ■	✕ ● ■	✕ ● ■	✕ ● ■	✕ ●	✕ ●	✕ ●	✕ ●	✕ ●
40	✕ ● ■	✕ ● ■	✕ ● ■	✕ ● ■	✕ ● ■	✕ ●	✕ ●	✕ ●	✕ ●	✕ ●
50		✕ ● ■	✕ ● ■	✕ ● ■	✕ ● ■	✕ ●	✕ ●	✕ ●	✕ ●	✕ ●
63		✕ ● ■	✕ ● ■	✕ ● ■	✕ ● ■	✕ ●	✕ ●	✕ ●	✕ ●	✕ ●
80		✕ ● ■	✕ ● ■	✕ ● ■	✕ ● ■	✕ ●	✕ ●	✕ ●	✕ ●	✕ ●
100		✕ ● ■	✕ ● ■	✕ ● ■	✕ ● ■	✕ ●	✕ ●	✕ ●	✕ ●	✕ ●

## ESEMPIO DI CODIFICA

<b>32</b>	<b>M</b>	<b>2</b>	<b>A</b>	<b>032</b>	<b>A</b>	<b>050</b>	
-----------	----------	----------	----------	------------	----------	------------	--

<b>32</b>	SERIE	
<b>M</b>	VERSIONE M = filetto stelo maschio, montato con dado stelo Mod. U F = filetto stelo femmina R = antirotazione con flangia (no semplice effetto)	
<b>2</b>	FUNZIONAMENTO 1 = semplice effetto, molla anteriore 2 = doppio effetto 3 = doppio effetto, stelo passante 4 = semplice effetto, molla posteriore	SIMBOLI PNEUMATICI CS06 CD08 CD12 CS08
<b>A</b>	CARATTERISTICHE MATERIALI A = testate e profilo in AL anodizzato - pistone in AL anodizzato guarnizione stelo, OR testate e guarnizione pistone in PU	
<b>032</b>	ALESAGGIO 020 = 20 mm - 025 = 25 mm - 032 = 32 mm - 040 = 40 mm 050 = 50 mm - 063 = 63 mm - 080 = 80 mm - 100 = 100 mm	
<b>A</b>	TIPO COSTRUTTIVO A = standard	
<b>050</b>	CORSA (vedi tabella)	
	= standard S = speciale V = guarnizione stelo in FKM W = alte temperature (doppio effetto non magnetico con guarnizioni in FKM per alte temperature 140°)	

## SIMBOLI PNEUMATICI

I simboli pneumatici indicati nell'ESEMPIO DI CODIFICA sono riportati di seguito.

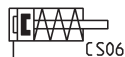
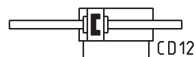
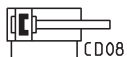

**ACCESSORI DISPONIBILI PER LA SERIE 32**



Snodo sferico maschio  
Mod. GY



Dado stelo Mod. U



Spinotto Mod. S

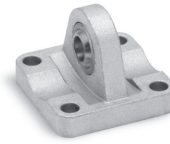

Cerniera con snodo  
Mod. R



Giunto compensatore  
Mod. GKF



Snodo sferico Mod. GA

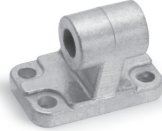

Supp. 90° per cerniera  
femmina Mod. ZC

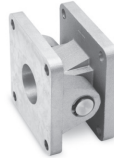

Combinazione di  
accessori Mod. C+L+S

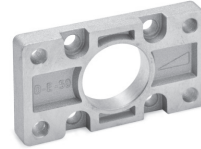

Flangia anteriore e post.  
Mod. D-E



Snodo autoallineante  
Mod. GK



Controcerniera Mod. I



Piedini Mod. B

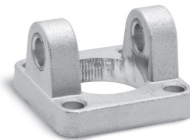

Cerniera femmina ant.  
Mod. H e C-H

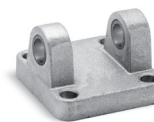

Cerniera femmina post.  
Mod. C e C-H

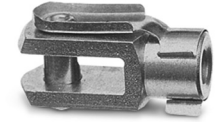

Forcella Mod. G

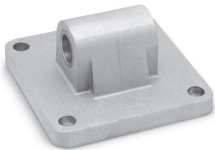

Cerniera maschio post.  
Mod. L



Tutti gli accessori sono forniti separatamente al cilindro.

Diagrammi carichi ammissibili

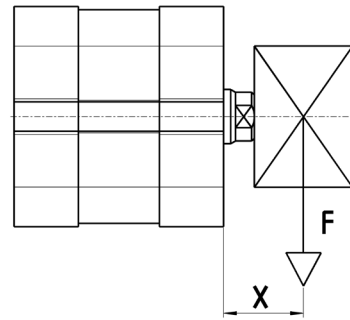
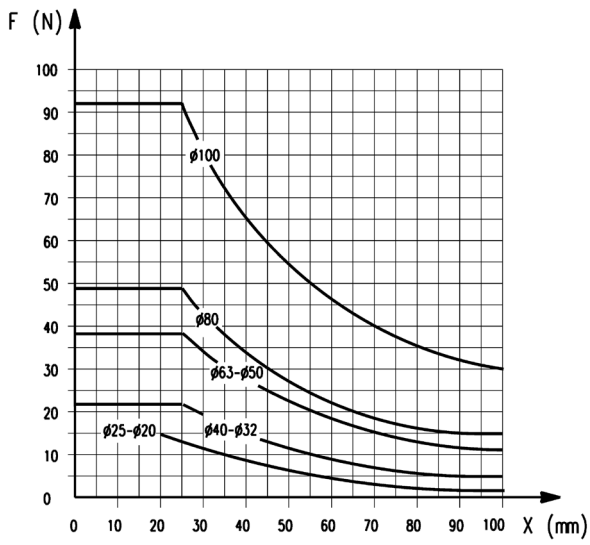

Standard.  
Carico trasversale ( F ) in funzione della sporgenza ( X )

Diagrammi carichi ammissibili

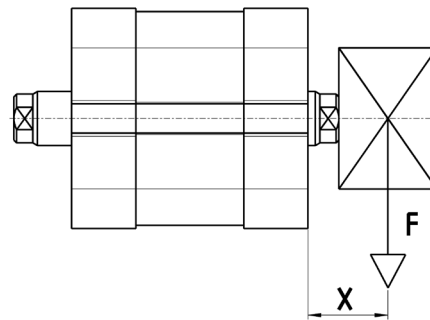
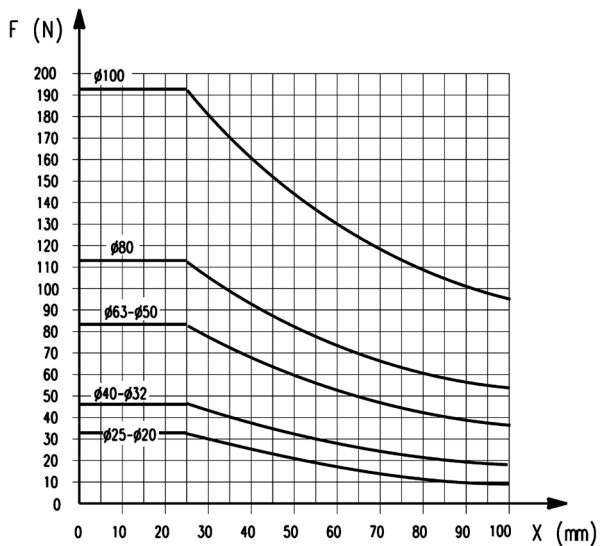

Stelo passante.  
Carico trasversale ( F ) in funzione della sporgenza ( X )

**Diagrammi carichi ammissibili**

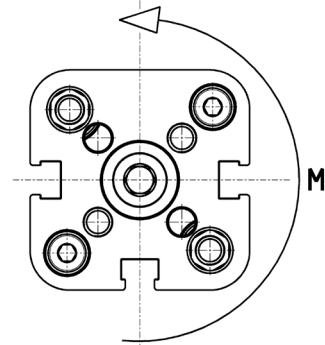
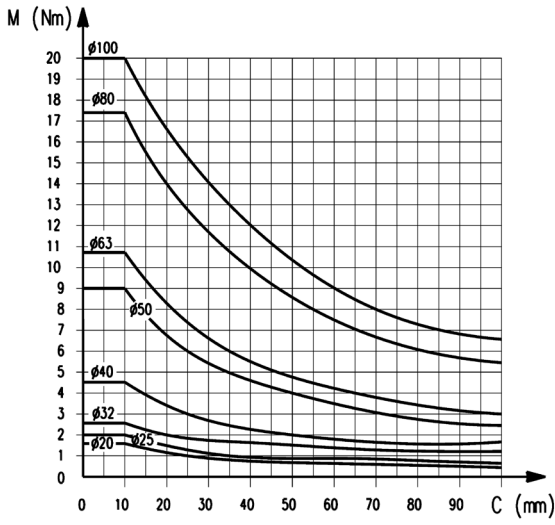

E' possibile realizzare corse come indicato nelle caratteristiche generali in assenza di carichi radiali e momenti torcenti. Qualora l'utilizzo del cilindro preveda carichi radiali, attenersi alla sporgenza massima del baricentro. In presenza di momenti torcenti, attenersi alla corsa massima riportata nei grafici.

Momento torcente ( M ) in funzione della corsa ( C ).

**Diagrammi carichi ammissibili**

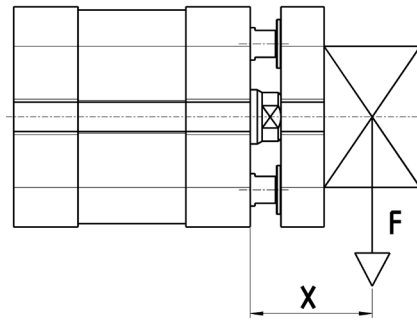
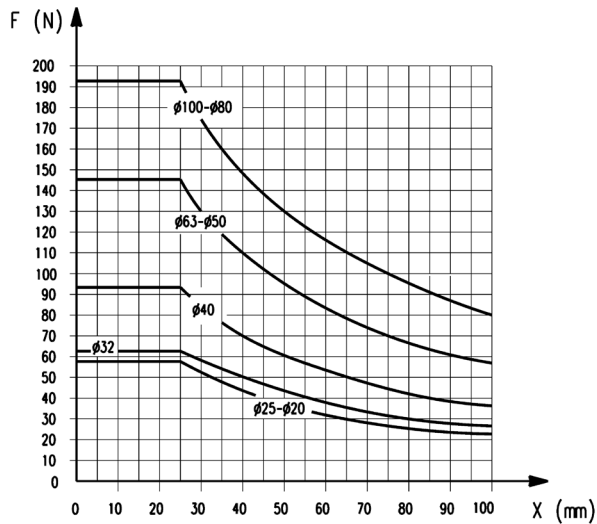

Antitrotazione.  
Carico trasversale ( F ) in funzione della sporgenza ( X ).

## Diagrammi carichi ammissibili

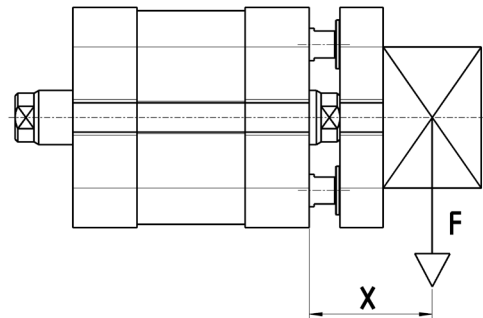
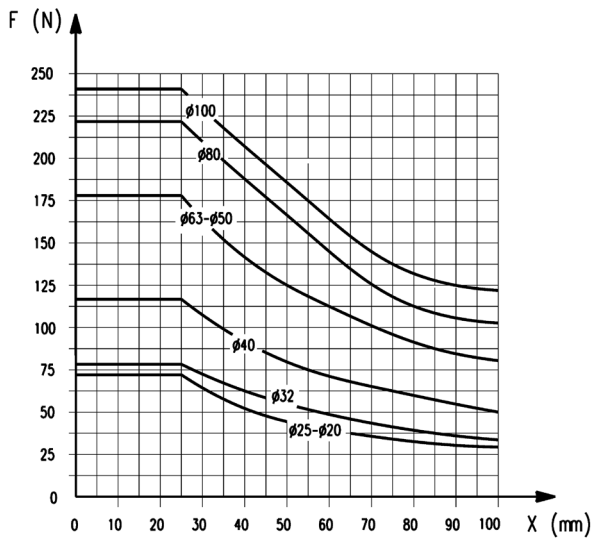

Antirotazione stelo passante.  
Carico trasversale (F) in funzione della sporgenza (X).

## Esempi di fissaggio

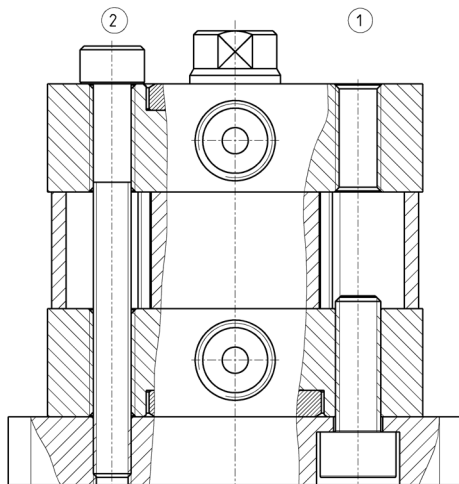

Esempio di fissaggio per Cilindri del  $\varnothing$  32; 40; 50; 63; 80; 100.  
1 = Fissaggio dal basso  
2 = Fissaggio dall'alto

N.B. Per i fissaggi dall'alto con viti passanti attraverso il corpo del cilindro è consigliabile usare viti amagnetiche.

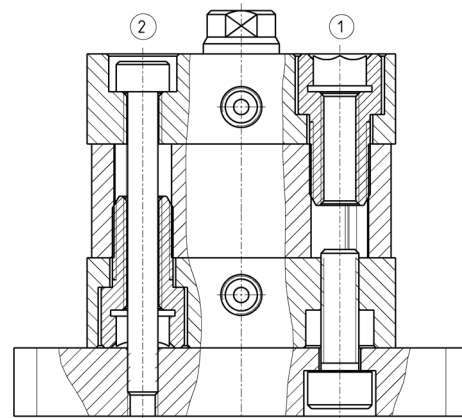

Esempio di fissaggio per Cilindri dal  $\varnothing$  20 ÷ 25.  
1 = Fissaggio dal basso  
2 = Fissaggio dall'alto

N.B. Per i fissaggi dall'alto con viti passanti attraverso il corpo del cilindro è consigliabile usare viti amagnetiche.

**Cilindri compatti magnetici Mod. 32F e 32M**



+ = sommare la corsa  
1 = scanalatura per sensore

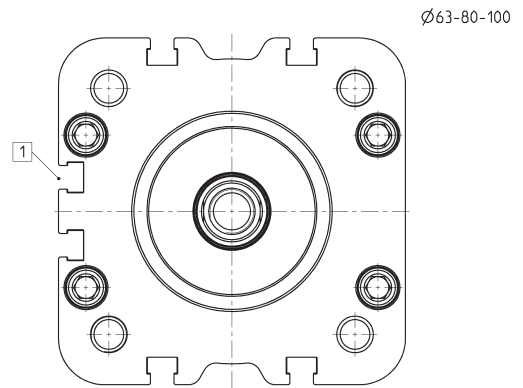
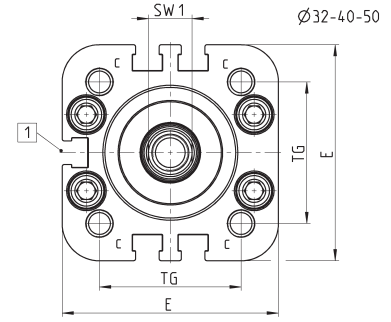
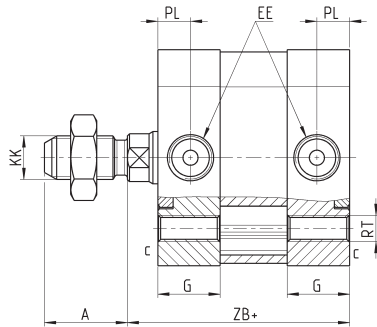
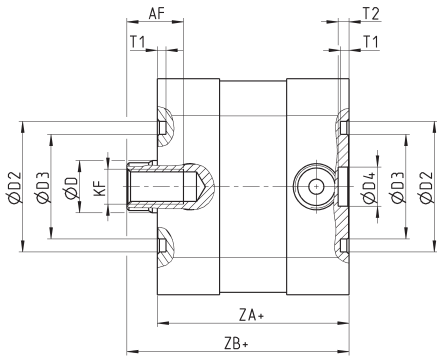
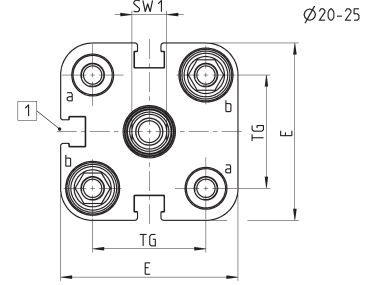
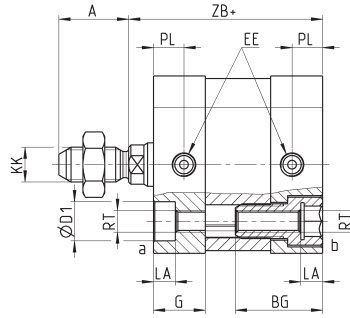
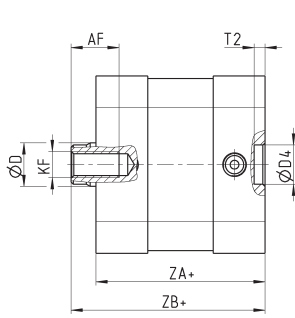

INGOMBRI																						
Ø	A	AF	BG	G	ØD	D1	ØD2	ØD3	ØD4	E	EE	KF	KK	LA	PL	RT	SW1	T1	T2	TG	ZA	ZB
20	16	11	20	10,9	10	9	-	-	9	35,8	M5	M6	M8X1,25	5	6,5	M5	8	-	2,5	22	36,8	42,5
25	16	11	20	11,9	10	9	-	-	9	40,7	M5	M6	M8X1,25	5	7	M5	8	-	2,5	26	38,8	44,5
32	19	13	-	14,3	12	-	30	24	9	49,6	G1/8	M8	M10X1,25	-	7,6	M6	10	2	2,5	32,5	44	51
40	19	13	-	14,3	12	-	35	29	9	57	G1/8	M8	M10X1,25	-	7,6	M6	10	2	2,5	38	45	52
50	22	16	-	14,3	16	-	40	34	12	69,6	G1/8	M10	M12X1,25	-	7,6	M8	13	2	3	46,5	45	53
63	22	16	-	14	16	-	45	39	12	79,6	G1/8	M10	M12X1,25	-	7,6	M8	13	2	3	56,5	49	57
80	28	20	-	14,8	20	-	45	39	12	95,6	G1/8	M12	M16X1,5	-	7,7	M10	17	2	3	72	54	63,5
100	28	20	-	17,8	25	-	55	49	12	115,6	G1/8	M12	M16X1,5	-	8	M10	22	2	3	89	66,8	76,5

**Cilindri compatti magnetici Mod. 32F3 e 32M3**



+ = sommare la corsa  
 ++ = sommare due volte la corsa  
 1 = scanalatura per sensore

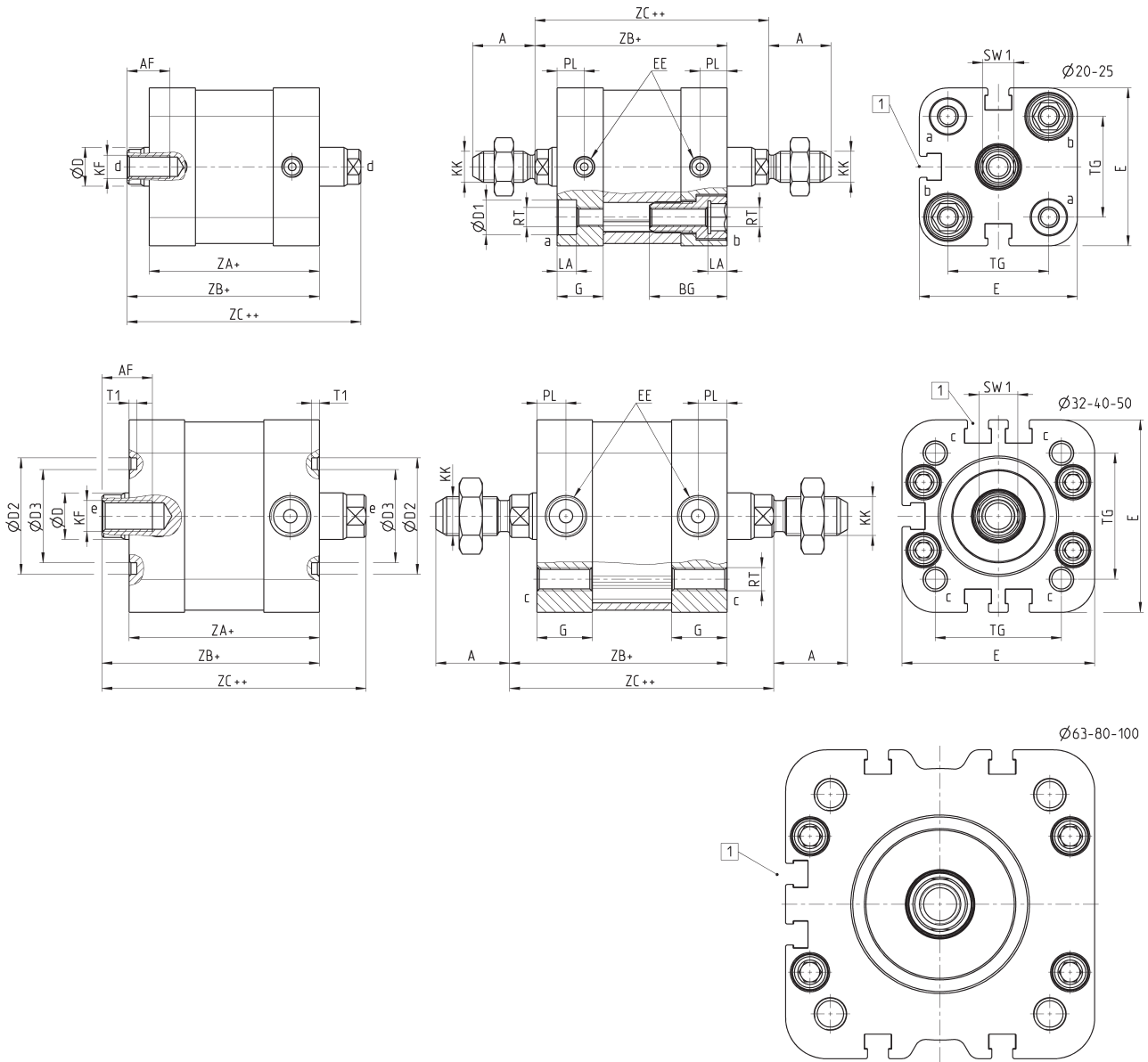

INGOMBRI																					
Ø	A	AF	BG	G	ØD	ØD1	ØD2	ØD3	E	EE	KF	KK	LA	PL	RT	SW1	T1	TG	ZA	ZB	ZC
20	16	11	20	10,9	10	9	-	-	35,8	M5	M6	M8X1,25	5	6,5	M5	8	-	22	36,8	42,5	48,2
25	16	11	20	11,9	10	9	-	-	40,7	M5	M6	M8X1,25	5	7	M5	8	-	26	38,8	44,5	50,2
32	19	13	-	14,3	12	-	30	24	49,6	G1/8	M8	M10X1,25	-	7,6	M6	10	2	32,5	44	51	58
40	19	13	-	14,3	12	-	35	29	57	G1/8	M8	M10X1,25	-	7,6	M6	10	2	38	45	52	59
50	22	16	-	14,3	16	-	40	34	69,6	G1/8	M10	M12X1,25	-	7,6	M8	13	2	46,5	45	53	61
63	22	16	-	14	16	-	45	39	79,6	G1/8	M10	M12X1,25	-	7,6	M8	13	2	56,5	49	57	65
80	28	20	-	14,8	20	-	45	39	95,6	G1/8	M12	M16X1,5	-	7,7	M10	17	2	72	54	63,5	73
100	28	20	-	17,8	25	-	55	49	115,6	G1/8	M12	M16X1,5	-	8	M10	22	2	89	66,8	76,5	86,2

Prodotti destinati all'industria.  
 Condizioni generali di vendita disponibili sul sito [www.camozzi.com](http://www.camozzi.com).



**Cilindri compatti magnetici Mod. 32R**

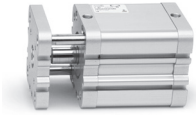

+ = sommare la corsa  
++ = sommare due volte la corsa  
1 = scanalatura per sensore

CILINDRI SERIE 32

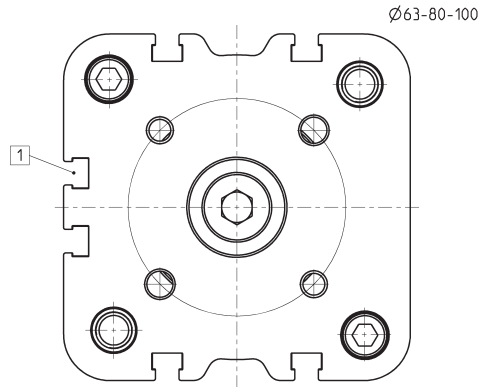
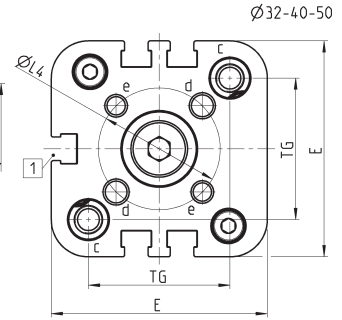
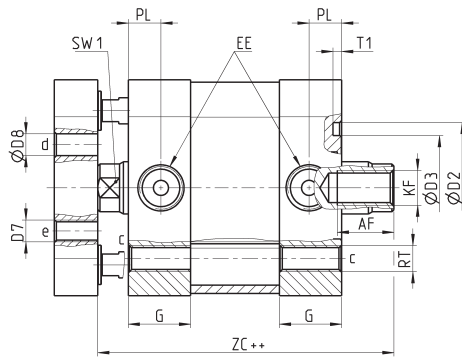
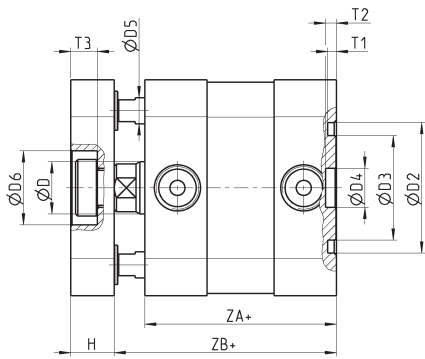
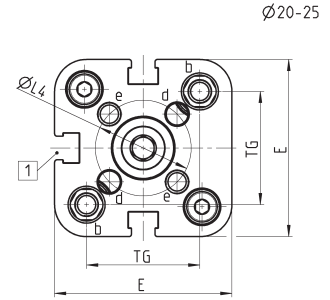
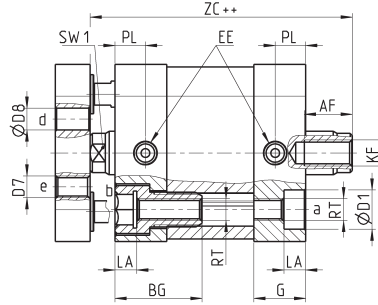
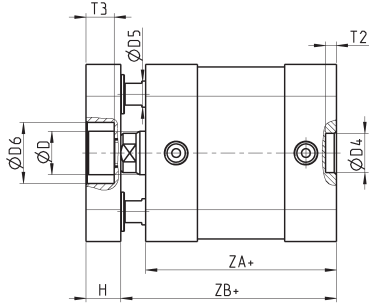

INGOMBRI																												
Ø	AF	BG	G	ØD	ØD1	ØD2	ØD3	ØD4	ØD5	ØD6	D7	ØD8	E	EE	H	KF	LA	ØL4	PL	RT	SW1	T1	T2	T3	TG	ZA	ZB	ZC
20	11	20	10.9	10	9	-	-	9	6	-	M4	4	35.8	M5	8	M6	5	17	6.5	M5	8	-	2.5	-	22	36.8	42.5	48.2
25	11	20	11.9	10	9	-	-	9	6	14	M5	5	40.7	M5	8	M6	5	22	7	M5	8	-	2.5	6.5	26	38.8	44.5	50.2
32	13	-	14.3	12	-	30	24	9	6	17	M5	5	49.6	G1/8	10	M8	-	28	7.6	M6	10	2	2.5	6	32.5	44	51	58
40	13	-	14.3	12	-	35	29	9	6	17	M5	5	57	G1/8	10	M8	-	33	7.6	M6	10	2	2.5	6	38	45	52	59
50	16	-	14.3	16	-	40	34	12	10	22	M6	6	69.6	G1/8	12	M10	-	42	7.6	M8	13	2	3	7	46.5	45	53	61
63	16	-	14	16	-	45	39	12	10	22	M6	6	79.6	G1/8	12	M10	-	50	7.6	M8	13	2	3	7	56.5	49	57	65
80	20	-	14.8	20	-	45	39	12	12	24	M8	8	95.6	G1/8	14	M12	-	65	7.7	M10	17	2	3	10.5	72	54	63.5	73
100	20	-	18	25	-	55	49	12	12	24	M10	10	115.6	G1/8	14	M12	-	80	8	M10	22	2	3	10.5	89	67	76.7	86.2

## Ancoraggio a piedini Mod. B

Materiale: Acciaio zincato



La fornitura comprende:  
N° 2 Piedini  
N° 4 Viti

+ = sommare la corsa

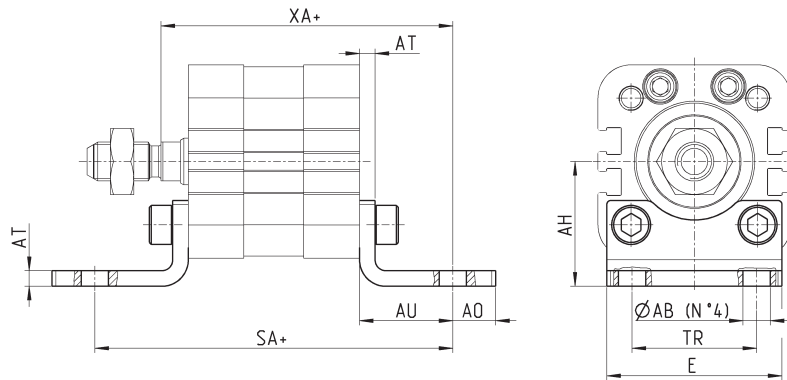

INGOMBRI										
Mod.	Ø	ØAB	AH	AO	AU	AT	E	TR	SA	XA
B-32-20	20	6,5	27	9	16	4	35	22	68,8	58,5
B-31-25	25	6,5	29	9	16	4	39	26	70,8	60,5
B-41-32	32	7	32	11	24	4	45	32	92	75
B-41-40	40	10	36	15	28	4	53,5	36	101	80
B-41-50	50	10	45	15	32	4	62,5	45	109	85
B-41-63	63	10	50	15	32	5	73	50	113	89
B-41-80	80	12	63	20	41	6	92	63	136	104,5
B-41-100	100	14,5	71	25	41	6	108,5	71	148,8	117,5

## Ancoraggio a cerniera femmina posteriore Mod. C e C-H

Materiale: Alluminio

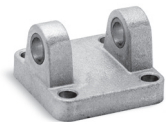

La fornitura comprende:  
N° 1 Cerniera Femmina  
N° 4 Viti

+ = sommare la corsa

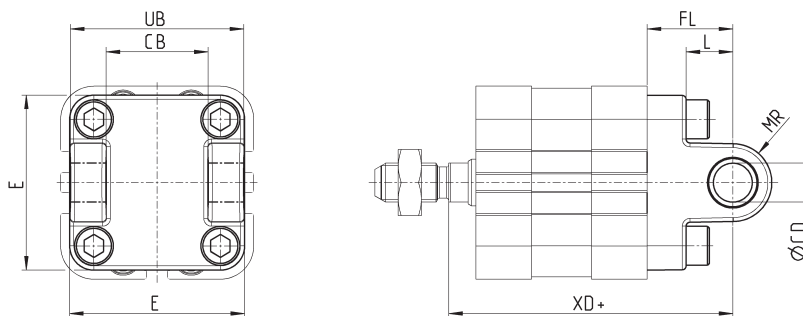

INGOMBRI									
Mod.	Ø	ØCD	E	CB	UB	L	FL	MR	XD
C-41-32	32	10	45	26	45	12	22	10	73
C-41-40	40	12	53,5	28	52	15	25	12	77
C-41-50	50	12	62,5	32	60	15	27	13	80
C-H-41-63	63	16	73	40	70	20	32	17	89
C-H-41-80	80	16	92	50	90	24	36	17	99,5
C-H-41-100	100	20	108,5	60	110	29	41	21	117,5

## Ancoraggio a cerniera femmina anteriore Mod. H e C-H

Materiale: Alluminio

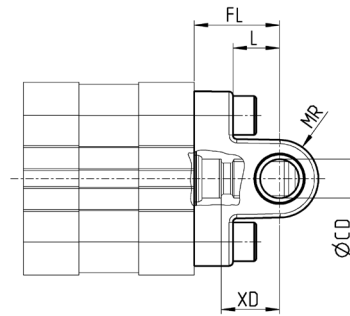
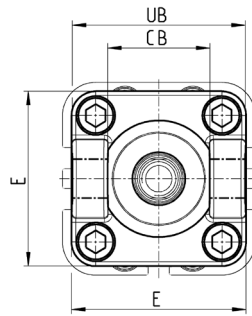
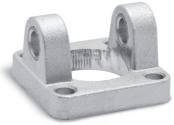

La fornitura comprende:  
N° 1 Cerniera Femmina  
N° 4 Viti

CILINDRI SERIE 32

INGOMBRI									
Mod.	Ø	ØCD	E	CB	UB	L	FL	MR	XD
H-41-32	32	10	45	26	45	12	22	10	15
H-41-40	40	12	53,5	28	52	15	25	12	18
H-41-50	50	12	62,5	32	60	15	27	13	19
H-60-63	63	16	73	40	70	20	32	17	24
C-H-41-80	80	16	92	50	90	24	36	17	26,5
C-H-41-100	100	20	108,5	60	110	29	41	21	31,3

## Ancoraggio a flangia anteriore e posteriore Mod. D-E

Materiale: Acciaio zincato per i Ø 20 - Ø 25; Alluminio dal Ø 32 - Ø 100

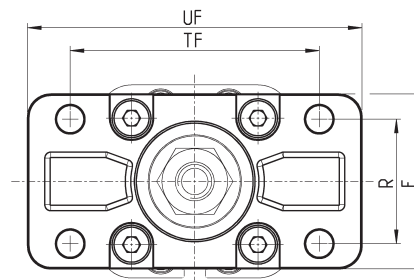
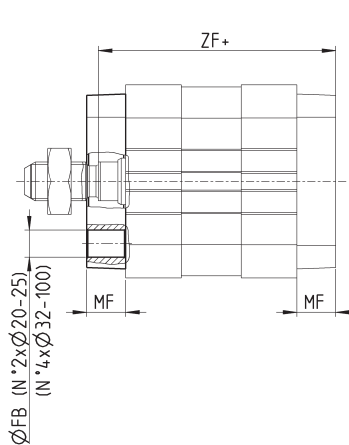
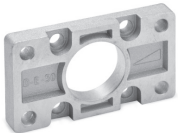

La fornitura comprende:  
N° 1 Flangia  
N° 4 Viti

+ = sommare la corsa

INGOMBRI								
Mod.	Ø	ØFB	E	MF	R	TF	UF	ZF
D-E-32-20	20	6,6	36	10	-	55	70	52,5
D-E-32-25	25	6,6	40	10	-	60	76	54,5
D-E-41-32	32	7	45	10	32	64	86	61
D-E-41-40	40	9	52	10	36	72	88	62
D-E-41-50	50	9	63	12	45	90	110	65
D-E-41-63	63	9	73	12	50	100	116	69
D-E-41-80	80	12	95	16	63	126	148	79,5
D-E-41-100	100	14	115	16	75	150	176	92,5

## Ancoraggio a cerniera maschio posteriore Mod. L

Materiale: Alluminio

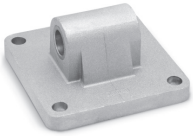

La fornitura comprende:  
N° 1 Cerniera maschio  
N° 4 Viti

+ = sommare la corsa

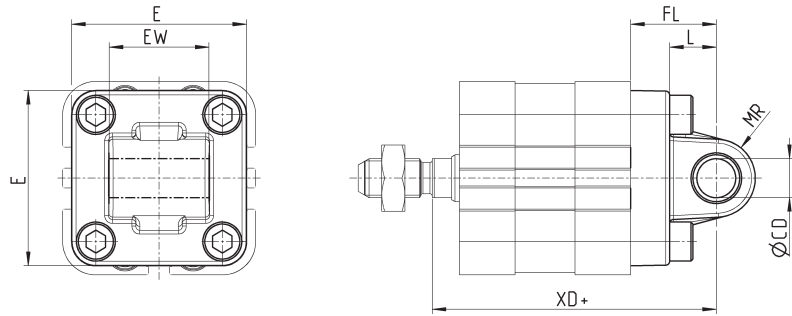

INGOMBRI								
Mod.	Ø	ØCD	E	EW	L	FL	MR	XD
L-32-20	20	8	34	16	14	20	8	62,5
L-32-25	25	8	38	16	14	20	8	64,5
L-41-32	32	10	45	26	12	22	10	73
L-41-40	40	12	53,5	28	15	25	13	77
L-41-50	50	16	62,5	32	15	27	13	80
L-41-63	63	16	73	40	20	32	17	89
L-41-80	80	20	92	50	24	36	17	99,5
L-41-100	100	20	108,5	60	29	41	21	117,5

## Ancoraggio a cerniera maschio post. con snodo sferico Mod. R\*

\* Ancoraggio non a norma ISO 15552  
Materiale: Alluminio

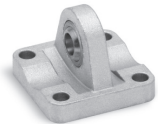

La fornitura comprende:  
N° 1 Cerniera snodata  
N° 4 Viti

+ = sommare la corsa

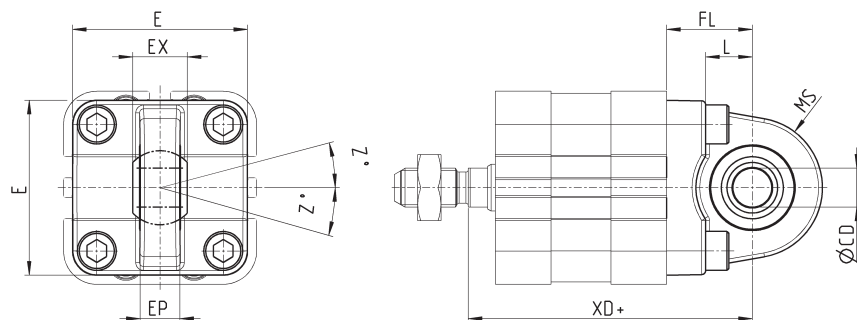

INGOMBRI										
Mod.	Ø	ØCD	E	EX	EP	L	FL	MS	XD	Z°
R-41-32	32	10	45	14	10,5	12	22	18	73	4
R-41-40	40	12	53,5	16	12	15	25	18	77	4
R-41-50	50	12 *	62,5	16 *	12 *	15	27	21	80	4
R-41-63	63	16	73	21	15	20	32	23	89	4
R-41-80	80	16 *	92	21 *	15 *	24	36	28	99,5	4
R-41-100	100	20	108,5	25	18	29	41	30	117,5	4

**Combinazione di accessori modelli C+L+S**

Materiale: Alluminio

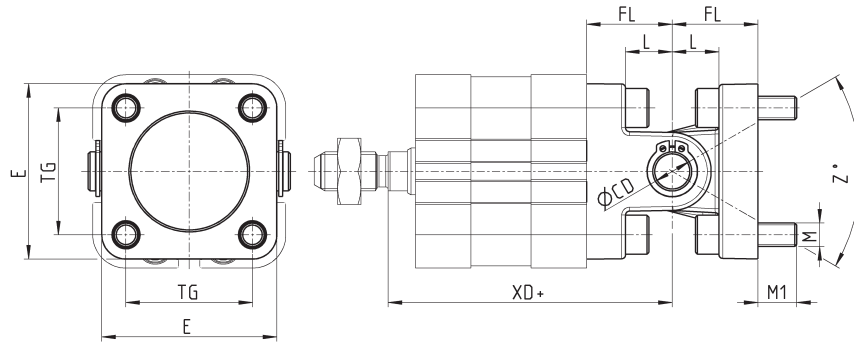

+ = sommare la corsa

CILINDRI SERIE 32

INGOMBRI										
Mod.	∅	∅CD	E	L	FL	M	M1	TG	XD+	Z° (max)
C+L+S	32	10	45	12	22	M6	10	32.5	73	30
C+L+S	40	12	53.5	15	25	M6	10	38	77	40
C+L+S	50	12	62.5	15	27	M8	13	46.5	80	25
C+L+S	63	16	73	20	32	M8	13	56.5	89	36
C+L+S	80	16	92	24	36	M10	16	72	99.5	34
C+L+S	100	20	108.5	29	41	M10	16	89	117.5	38

**Supporto a 90° per cerniera femmina posteriore Mod. ZC**

Materiale: Alluminio

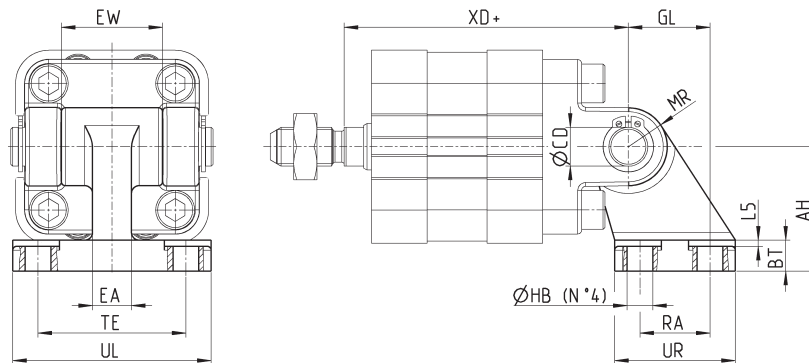
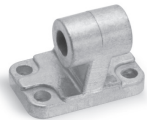

La fornitura comprende:  
N° 1 Supporto maschio

+ = sommare la corsa

INGOMBRI															
Mod.	∅	AH	BT	∅CD	EA	EW	GL	∅HB	L5	MR	RA	UL	UR	TE	XD
ZC-32	32	32	8	10	10	26	21	6,6	1,6	10	18	51	31	38	73
ZC-40	40	36	10	12	15	28	24	6,6	1,6	11	22	54	35	41	77
ZC-50	50	45	12	12	16	32	33	9	1,6	13	30	65	45	50	80
ZC-63	63	50	14	16	16	40	37	9	1,6	15	35	67	50	52	89
ZC-80	80	63	14	16	20	50	47	11	2,5	15	40	86	60	66	99,5
ZC-100	100	71	17	20	20	60	55	11	2,5	19	50	96	70	76	117,5

## Supporto 90° per cerniera femmina posteriore Mod. I

Materiale: Acciaio zincato



La fornitura comprende:  
N° 1 Supporto femmina  
N° 2 Seeger  
N° 1 Spinotto

+ = sommare la corsa

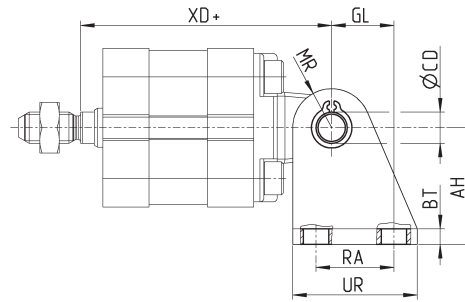
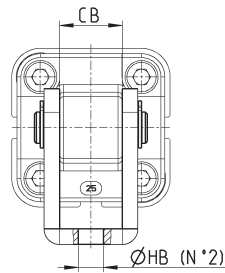

INGOMBRI											
Mod.	Ø	AT	BT	ØCD	CB	GL	ØHB	MR	RA	UR	XD
I-20-25	20	30	4	8	16,1	16	6,5	10	20	32	62,5
I-20-25	25	30	4	8	16,1	16	6,5	10	20	32	64,5

## Spinotto Mod. S

Materiali: Spinotto INOX, Seeger Acciaio



La fornitura comprende:  
N° 1 Spinotto  
N° 2 Seeger

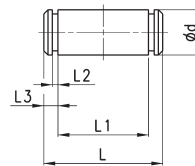

INGOMBRI						
Mod.	Ø	D	L	L1	L2	L3
S-32	32	10	52	46	1,1	3
S-40	40	12	59	53	1,1	3
S-50	50	12	67	61	1,1	3
S-63	63	16	77	71	1,1	3
S-80	80	16	97	91	1,1	3
S-100	100	20	121	111	1,3	5

**Forcella Mod. G**



ISO 8140  
Materiale: Acciaio zincato

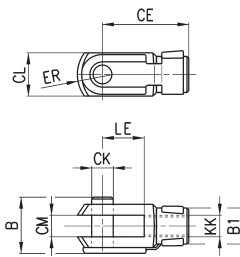

INGOMBRI										
Mod.	∅	∅ <sub>CK</sub>	LE	CM	CL	ER	CE	KK	B	∅ <sub>B1</sub>
G-20	20-25	8	16	8	16	10	32	M8X1,25	22	14
G-25-32	32-40	10	20	10	20	12	40	M10x1,25	26	18
G-40	50-63	12	24	12	24	14	48	M12x1,25	32	20
G-50-63	80-100	16	32	16	32	19	64	M16x1,5	40	26

**Snodo sferico maschio Mod. GY**

Materiale: Zama e Acciaio zincato

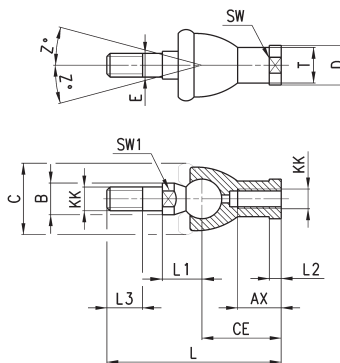

INGOMBRI																	
Mod.	∅	KK	L	CE	L2	AX	SW	SW1	L1	L3	∅ <sub>T</sub>	∅ <sub>D</sub>	E	∅ <sub>B</sub>	∅ <sub>C</sub>	Z	
GY-20	20-25	M8X1,25	65	32	5	16	14	10	16	12	12,5	13	6	10	20	15	
GY-32	32-40	M10X1,25	74	35	6,5	18	17	11	19,5	15	15	19	10	14	28	15	
GY-40	50-63	M12X1,25	84	40	6,5	20	19	17	21	17	17,5	22	12	19	32	15	
GY-50-63	80-100	M16X1,5	112	50	8	27	22	19	27,5	23	22	27	16	22	40	11	

## Snodo sferico Mod. GA



ISO 8139  
Materiale: acciaio zincato

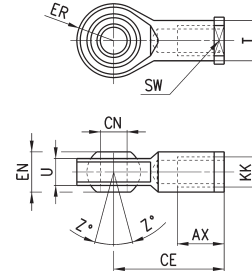

INGOMBRI											
Mod.	Ø	øCN	U	EN	ER	AX	CE	KK	øT	Z	SW
GA-20	20-25	8	9	12	12	16	36	M8X1,25	12,5	6,5	14
GA-32	32-40	10	10,5	14	14	20	43	M10x1,25	15	6,5	17
GA-40	50-63	12	12	16	16	22	50	M12X1.25	17,5	6,5	19
GA-50-63	80-100	16	15	21	21	28	64	M16x1,5	22	7,5	22

## Dado stelo Mod. U



UNI EN ISO 4035  
Materiale: Acciaio zincato

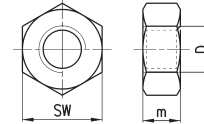

INGOMBRI				
Mod.	Ø	D	M	SW
U-20	20-25	M8X1.25	5	13
U-25-32	32-40	M10X1,25	6	17
U-40	50-63	M12X1,25	7	19
U-50-63	80-100	M16X1,5	8	24

## Boccola di centraggio Mod. TR



La fornitura comprende:  
N° 1 Anello di centraggio in AL anodizzato

Concepiti sia per il centraggio delle testate posteriori ed anteriori con gli ancoraggi mod. B/D-E/C/C-H/H/L/R, che per il centraggio del cilindro in fase di montaggio.

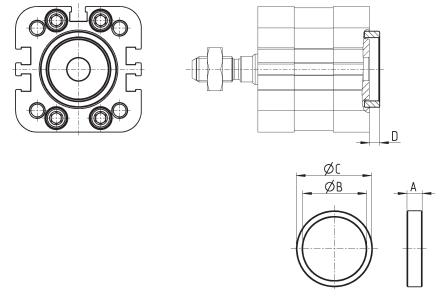

INGOMBRI					
Mod.	Ø	A	øB	øC	D
TR-32-32	32	6	25	30	4
TR-32-40	40	6	30	35	4
TR-32-50	50	6	35	40	4
TR-32-63	63-80	7	40	45	5
TR-32-100	100	7	50	55	5

## Perno di centraggio Mod. TS-32-20

Materiale: Alluminio anodizzato

Concepito per il centraggio sia delle testate post. con gli ancoraggi L-32-20 / L-32-25 che del cilindro in fase di montaggio, è utilizzabile anche nei fori "a" delle testate ant./post. di cil. Ø20-Ø25 o nel foro centrale delle testate post. di cil. Ø32-Ø40.

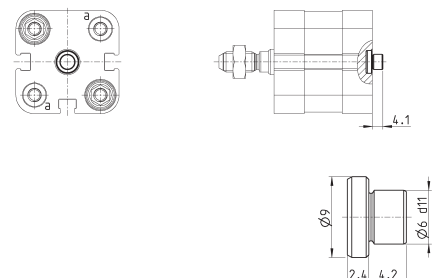

Mod.  
TS-32-20



### Snodo autoallineante Mod. GK

Solo per cilindri con stelo maschio

Materiale: Acciaio zincato

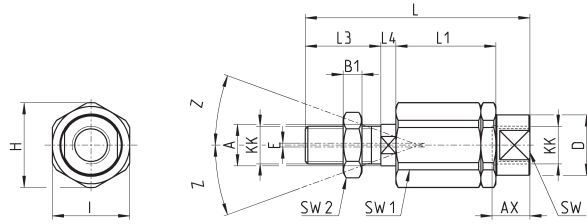

INGOMBRI																	
Mod.	Ø	KK	L	L1	L3	L4	ØA	ØD	H	I	SW	SW1	SW2	B1	AX	Z	E
<b>GK-20</b>	20-25	M8x1,25	57	26	21	5	8	12,5	19	17	11	7	13	4	16	4	2
<b>GK-25-32</b>	32-40	M10x1,25	71,5	35	20	7,5	14	22	32	30	19	12	17	5	22	4	2
<b>GK-40</b>	50-63	M12x1,25	75,5	35	24	7,5	14	22	32	30	19	12	19	6	22	4	2
<b>GK-50-63</b>	80-100	M16x1,5	104	53	32	10	22	32	45	41	27	20	24	8	30	3	2

### Giunto compensatore Mod. GKF

Materiale: Acciaio zincato

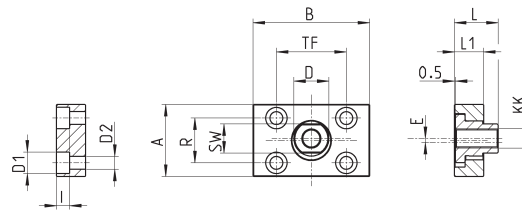

INGOMBRI														
Mod.	Ø	KK	A	B	R	TF	L	L1	I	ØD	ØD1	ØD2	SW	E
<b>GKF-20</b>	20-25	M8x1,25	30	35	20	25	22,5	10	-	14	5,5	-	13	1,5
<b>GKF-25-32</b>	32-40	M10x1,25	37	60	23	36	22,5	15	6,8	18	11	6,6	15	2
<b>GKF-40</b>	50-63	M12x1,25	56	60	38	42	22,5	15	9	20	15	9	15	2,5
<b>GKF-50-63</b>	80-100	M16x1,5	80	80	58	58	26,5	15	10,5	25	18	11	22	2,5