

Cilindri ISO 15552 Serie 63

Nuove versioni

Semplice e doppio effetto, magnetici, ammortizzati
 ø 32, 40, 50, 63, 80, 100, 125 mm



Gli attuatori pneumatici Serie 63 sono stati sviluppati per garantire elevate prestazioni e versatilità.

Grazie al nuovo sistema di ammortizzatori pneumatici regolabili, i cilindri sono in grado di garantire sempre una regolazione ottimale riducendo sensibilmente la rumorosità dovuta all'impatto di fine corsa.

Oltre alla versione base, che può essere utilizzata in molteplici settori, sono state sviluppate soluzioni specifiche per l'utilizzo in applicazioni particolari quali alimentare, agricoltura, sistemi tensionatori e ballerini, dosatori e in tutte quelle applicazioni che hanno delle condizioni ambientali di lavoro severe dal punto di vista della temperatura, corrosione o sicurezza.

- » Conformi alla normativa ISO 15552
- » Peso ridotto del 25%
- » Bassa rumorosità
- » Regolazione dell'ammortizzo più fine e graduale
- » Alta flessibilità e versatilità

VERSIONI DISPONIBILI:

- » Basso attrito
- » Movimento uniforme (bassa velocità)
- » Alte e basse temperature
- » Resistenza alla corrosione
- » Idrolisi
- » Alimentare
- » Funzionamento a secco
- » Ambienti sporchi e polverosi
- » Protezione con soffiutto
- » Back to back
- » Tandem e più posizioni
- » Con bloccastelo
- » Con verniciatura poliuretanica
- » ATEX

CARATTERISTICHE GENERALI

Costruzione	a profilo (con viti) e a tubo tondo (con tiranti)
Design	ISO 15552
Funzionamento	semplice effetto e doppio effetto
Fissaggio	a flangia anteriore / posteriore, con piedini, con cerniera anteriore / posteriore / snodata / intermedia
Corse min - max	10 ÷ 2500 mm
Temperatura d'esercizio	standard e basso attrito: 0°C ÷ 80°C (con aria secca -20°C); alte temperature (versione W): 0°C ÷ 150°C (con aria secca -20°C); basse temperature (versione Z): -40°C ÷ 60°C (con aria secca -40°C); basse temperature (versione Y): -50°C ÷ 60°C (con aria secca -50°C);
Temperatura di stoccaggio	0°C ÷ 80°C (con aria secca -20°C)
Pressione d'esercizio	1 ÷ 10 bar (standard, alte e basse temperature); 0.1 ÷ 10 bar (basso attrito)
Velocità	10 ÷ 1000 mm/sec, senza carico (standard, alte e basse temperature); 5 ÷ 1000 mm/sec, senza carico (basso attrito e movimento uniforme)
Fluido	aria filtrata in classe 7.8.4 secondo ISO 8573-1. Nel caso si utilizzasse aria lubrificata, si consiglia olio ISOVG32 e di non interrompere mai la lubrificazione.
Utilizzo con sensori	modello CSH

TABELLA CORSE STANDARD CILINDRI SERIE 63

■ = Semplice effetto, molla ant. (standard, alte e basse temperature); ▲ = Semplice effetto, molla post. (standard, alte e basse temp.);
 ✕ = Doppio effetto (standard, basso attrito, alte e basse temp.) Disponibili a richiesta altre corse fino ad un max di 2500 mm.

CORSE STANDARD														
Ø	25	50	75	80	100	125	150	160	200	250	300	320	400	500
32	■ ▲ ✕	■ ▲ ✕	■ ✕	✕	✕	✕	✕	✕	✕	✕	✕	✕	✕	✕
40	■ ▲ ✕	■ ▲ ✕	■ ✕	✕	✕	✕	✕	✕	✕	✕	✕	✕	✕	✕
50	■ ▲ ✕	■ ▲ ✕	■ ✕	✕	✕	✕	✕	✕	✕	✕	✕	✕	✕	✕
63	■ ▲ ✕	■ ▲ ✕	■ ✕	✕	✕	✕	✕	✕	✕	✕	✕	✕	✕	✕
80	■ ▲ ✕	■ ▲ ✕	■ ✕	✕	✕	✕	✕	✕	✕	✕	✕	✕	✕	✕
100		■ ▲ ✕	■ ✕	✕	✕	✕	✕	✕	✕	✕	✕	✕	✕	✕
125		■ ▲ ✕	■ ✕	✕	✕	✕	✕	✕	✕	✕	✕	✕	✕	✕

ESEMPIO DI CODIFICA

63	M	P	2	C	050	A	0200	W						
-----------	----------	----------	----------	----------	------------	----------	-------------	----------	--	--	--	--	--	--

63	SERIE	
M	VERSIONE: M = standard, magnetico V = movimento uniforme (no stick slip), magnetico L = basso attrito, magnetico	
P	CONSTRUZIONE: T = tubo tondo P = profilo	
2	FUNZIONAMENTO: 1 = semplice effetto, molla anteriore 2 = doppio effetto 6 = doppio effetto, stelo passante 7 = semplice effetto, stelo passante 9 = semplice effetto, molla posteriore	SIMBOLI PNEUMATICI: CS07/CS18 CD08 - CD09 - CD10 - CD11 CD13 CS11 CS14/CS17
C	AMMORTIZZO: N = non ammortizzato (paracolpi meccanici) C = ammortizzato da entrambi i lati F = ammortizzo anteriore R = ammortizzo posteriore	SIMBOLI PNEUMATICI: CD08 CD09/CD13 CD11 CD10
050	ALESAGGIO: 032 = 32 mm 040 = 40 mm 050 = 50 mm 063 = 63 mm	080 = 80 mm 100 = 100 mm 125 = 125 mm
A	TIPO COSTRUTTIVO: A = standard con dado stelo RL = cilindro con bloccastelo	DC = cilindro Back to back con accessorio DC [X1/X2] TR = cilindro Back to back per tubo tondo [X1/X2] F = cilindro con cerniera intermedia
0200	CORSA: = standard N = tandem / = più posizioni X1/X2 [X1<X2]	
W	TEMPERATURA: = standard (-20°/+80°) W = alte temperature (150°C)	Z = basse temperature (-40°C) Y = basse temperature (-50°C)
	RESISTENZA ALLA CORROSIONE: = standard C1 = dado stelo AISI 304, stelo AISI 304 C2 = viti testata trattate (profilo) o dadi tirante AISI 303 e tiranti AISI 420B (tubo tondo)	C3 = C2 + dado stelo AISI 316, stelo AISI 316 C4 = C1 + C2 C5 = C3 + testate con tripla protezione
	VARIANTI: = standard (filetto stelo maschio) F = filetto stelo femmina K = testate con trattamento kanigen L = senza guarnizione stelo (ingresso aria solo posteriore) V = guarnizione stelo FKM R = guarnizione stelo NBR U = utilizzo a secco	H = idrolisi A = utilizzo alimentare e frequenti lavaggi G = ambienti sporchi e polverosi (con raschiatore metallico e stelo AISI 420B cromato) B = cilindro con protezione stelo soffiato NBR B2 = cilindro con stelo passante e protezione stelo soffiato NBR su ambo i lati (___) = stelo prolungato ___ mm
	ALTRO: P = cilindro con rivestimento poliuretano RAL 7035	
	CERTIFICAZIONI: EX = ATEX	

SIMBOLI PNEUMATICI

I simboli pneumatici indicati nell'ESEMPIO DI CODIFICA sono riportati di seguito.

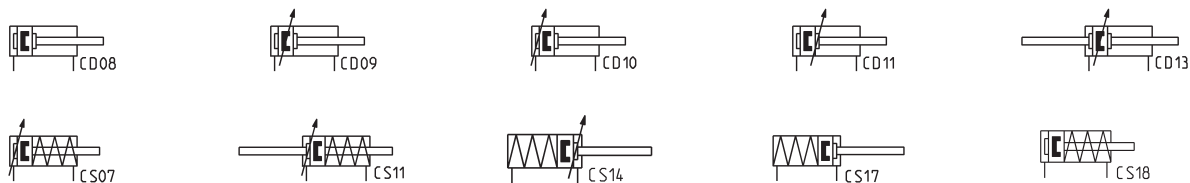

CILINDRI SERIE 63

MATERIALI

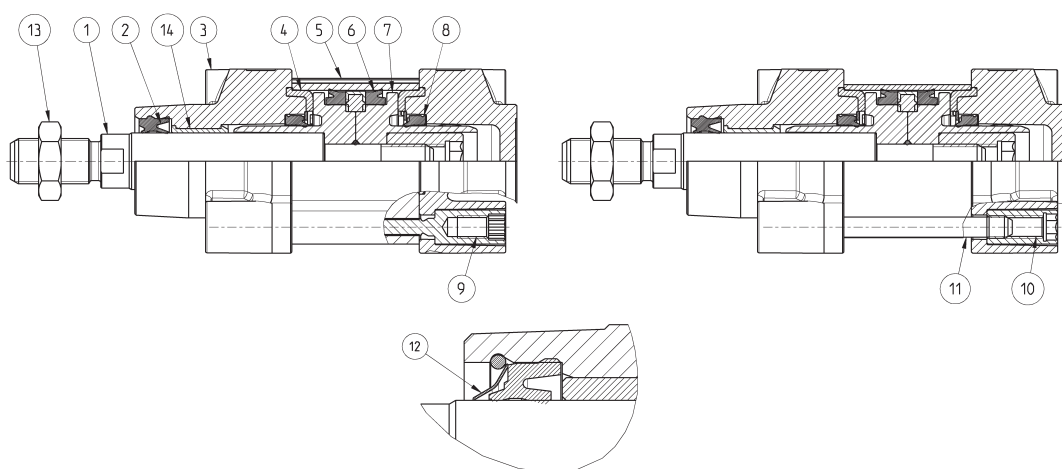

ELENCO COMPONENTI	Standard a profilo	Standard a tubo tondo	Basso attrito (L)	Raschiastelo (G)	Basse temperature (Z/Y)	Alte temperature (W)	Resistenza a corrosione (C1)
PARTI							
1 - Stelo	AISI 420B	AISI 420B	AISI 420B	AISI 420B cromato	AISI 420B cromato	AISI 420B	AISI 304
2 - Guarnizione stelo	PU	PU	NBR	NBR	PU per -40°C/-50°C	FKM	PU
3 - Testata	Alluminio	Alluminio	Alluminio	Alluminio	Alluminio	Alluminio	Alluminio
4 - Guarnizione di battuta	NBR	NBR	NBR	NBR	NBR per -40°C/-50°C	FKM	NBR
5 - Profilo estruso	Alluminio anodizzato	Alluminio anodizzato	Alluminio anodizzato	Alluminio anodizzato	Alluminio anodizzato	Alluminio anodizzato	Alluminio anodizzato
6 - Guarnizione pistone	PU	PU	NBR	PU	PU per -40°C/-50°C	FKM	PU
7 - Pistone	Tecnopolimero (ø 32) o alluminio (ø 40 ÷ 125)	Alluminio (ø 125) o tecnopolimero (ø 32 ÷ 100)	Alluminio	Alluminio	Alluminio	Alluminio	Alluminio
8 - Guarnizione di ammortizzo	PU	PU	PU	PU	PU	FKM	PU
9 - Vite autoformante	Acciaio zincato	-	Acciaio zincato	Acciaio zincato	Acciaio zincato	Acciaio zincato	Acciaio zincato
10 - Dado tirante	-	Acciaio zincato	Acciaio zincato	Acciaio zincato	AISI 303	Acciaio zincato	Acciaio zincato
11 - Tirante	-	Acciaio zincato	Acciaio zincato	Acciaio zincato	AISI 420B	Acciaio zincato	Acciaio zincato
12 - Raschiastelo	-	-	-	Ottone	Ottone	-	-
13 - Dado stelo	Acciaio zincato	Acciaio zincato	Acciaio zincato	Acciaio zincato	AISI 304	Acciaio zincato	AISI 304
14 - Boccola guida stelo	Tecnopolimero	Tecnopolimero	Tecnopolimero	Tecnopolimero	Tecnopolimero	Acciaio + PTFE	Tecnopolimero

Cilindri Serie 63 basso attrito - ESEMPI DI APPLICAZIONE

CILINDRI SERIE 63

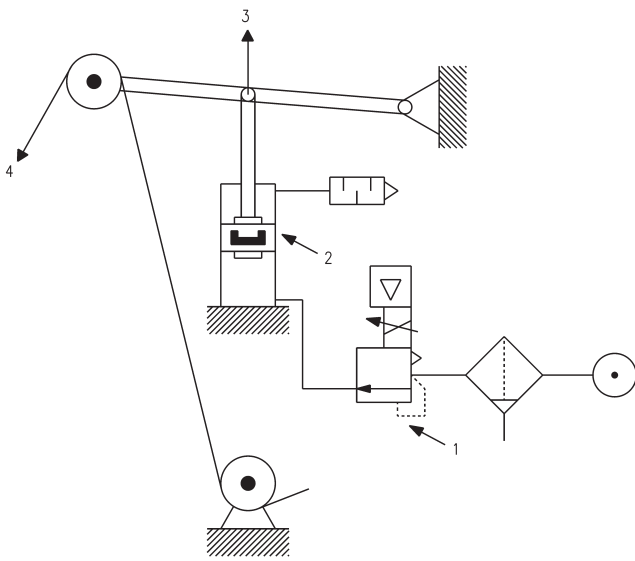

CILINDRO IN SPINTA

NOTE AL DISEGNO:

1. Regolatore di pressione di precisione o regolatore proporzionale
2. Cilindro basso attrito
3. Direzione forza
4. Nastro

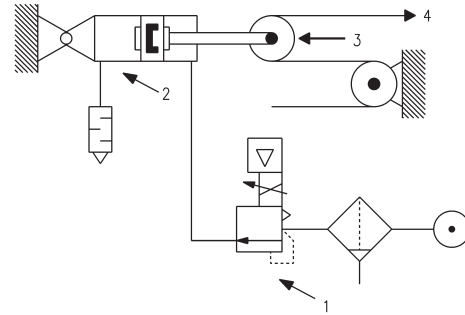

CILINDRO IN TRAZIONE

N.B. Per ottenere il massimo delle prestazioni, si consiglia di abbinare al cilindro a basso attrito un regolatore di pressione di precisione oppure un regolatore proporzionale come indicato nel disegno.

ACCESSORI DISPONIBILI PER LA SERIE 63

Snodo sferico maschio
Mod. GY

Dado stelo Mod. U

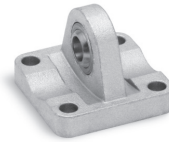
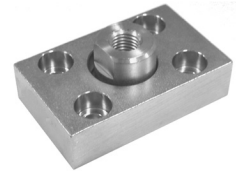

Spinotto Mod. S

Cerniera con snodo sferico
Mod. RGiunto compensatore
Mod. GKF

Snodo sferico Mod. GA

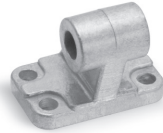
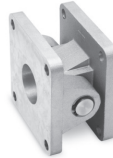
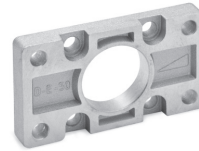
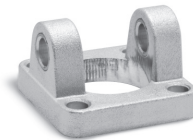
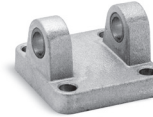
Supp. 90° per cerniera
femmina Mod. ZCCombinazione di
accessori Mod. C+L+SFlangia anteriore e
posteriore Mod. D-ESnodo autoallineante
Mod. GKAncoraggio a cerniera
interm. Mod. F-63, profiloAncoraggio a piedini Mod.
B-41Cerniera femmina
anteriore Mod. H e C-HCerniera femmina
posteriore Mod. C e C-H

Forcella Mod. G

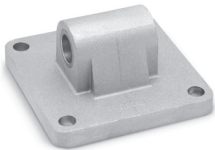
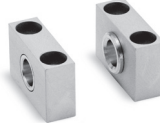
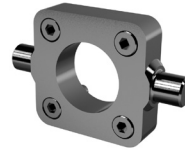
Cerniera maschio
posteriore Mod. LChiave smontaggio cil. Ø
80 e 100, tubo tondoSupporto per cerniera
intermedia Mod. BFAncoraggio a cerniera ant/
post lamata Mod. FNAccessorio per
contrapposti Mod. DC-63Ancoraggio a cerniera
interm. Mod. F, tubo tondo

Tutti gli accessori sono forniti separatamente al cilindro, fatta eccezione del dado stelo Mod. U

Cilindri Serie 63 a profilo, doppio effetto

Versioni: 63MP2... e 63LP2...

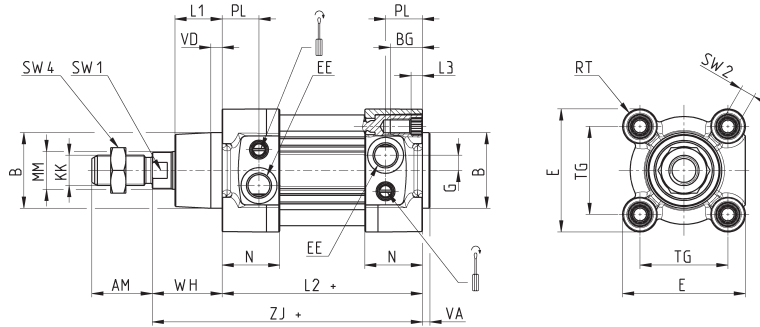

+ = sommare la corsa

INGOMBRI																							
Ø	ØMM	KK	ØB	PL	L1	AM	VA	EE	WH	L2	L3	ZJ	VD	N	BG	RT	G	TG	E	SW1	SW2	SW4	Corsa ammortizzo ant./post.
32	12	M10x1.25	30	18.5	18	22	4	G1/8	26	94	5.5	120	5	27	16	M6	5	32.5	47	10	6	17	17
40	16	M12x1.25	35	19	21	24	4	G1/4	30	105	5.5	135	5	30	16	M6	5	38	55	13	6	19	18
50	20	M16x1.5	40	19.5	25	32	4	G1/4	37	106	6	143	6	30.5	16	M8	8	46.5	65	17	8	24	20
63	20	M16x1.5	45	24	26	32	4	G3/8	37	121	6	158	6	37.5	16	M8	8	56.5	75	17	8	24	22
80	25	M20x1.5	45	23.5	30	40	4	G3/8	46	128	0	174	7	37	19	M10	8	72	93	22	6	30	25
100	25	M20x1.5	55	24	35	40	4	G1/2	51	138	0	189	7	39.5	19.5	M10	8	89	110	22	6	30	26
125	32	M27x2	60	28	42	54	6	G1/2	65	160	6	225	8	44	23	M12	10.5	110	135	27	12	41	33

Cilindri Serie 63 a tubo tondo, doppio effetto

Versioni: 63MT2... e 63LT2...

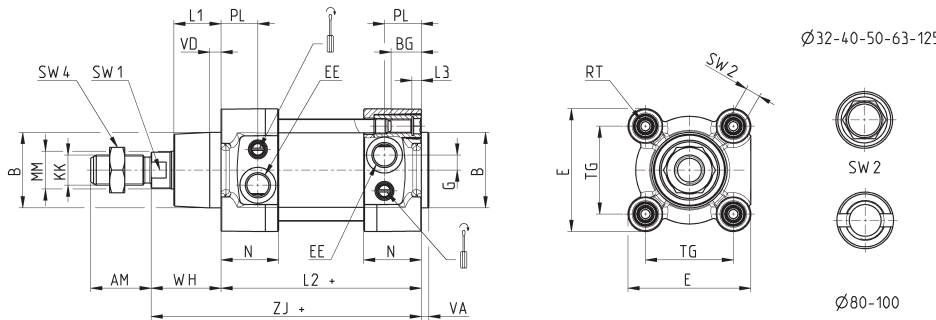

+ = sommare la corsa

Nota tabella:
* = chiave speciale
80-62/8C
(vedi accessori)

INGOMBRI																							
Ø	ØMM	KK	ØB	PL	L1	AM	VA	EE	WH	L2	L3	ZJ	VD	N	BG	RT	G	TG	E	SW1	SW2	SW4	Corsa ammortizzo ant./post.
32	12	M10x1.25	30	18.5	18	22	4	G1/8	26	94	5.5	120	5	27	16	M6	5	32.5	47	10	6	17	17
40	16	M12x1.25	35	19	21	24	4	G1/4	30	105	5.5	135	5	30	16	M6	5	38	55	13	6	19	18
50	20	M16x1.5	40	19.5	25	32	4	G1/4	37	106	6	143	6	30.5	16	M8	8	46.5	65	17	8	24	20
63	20	M16x1.5	45	24	26	32	4	G3/8	37	121	6	158	6	37.5	16	M8	8	56.5	75	17	8	24	22
80	25	M20x1.5	45	23.5	30	40	4	G3/8	46	128	0	174	7	37	19	M10	8	72	93	22	*	30	25
100	25	M20x1.5	55	24	35	40	4	G1/2	51	138	0	189	7	39.5	19.5	M10	8	89	110	22	*	30	26
125	32	M27x2	60	28	42	54	6	G1/2	65	160	6	225	8	44	23	M12	10.5	110	135	27	12	41	33

Cilindri Serie 63 a profilo, semplice effetto, molla anteriore

Versioni: 63MP1... e 63LP1...



+ = sommare la corsa

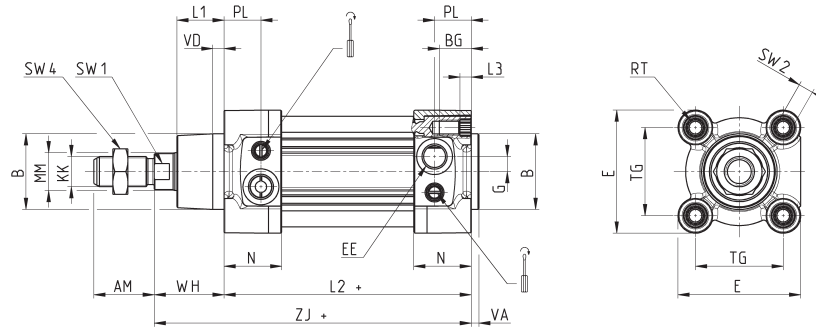

INGOMBRI																									
Ø	ØMM	KK	ØB	PL	L1	AM	VA	EE	WH	L2	L3	ZJ	VD	N	BG	RT	G	TG	E	SW1	SW2	SW4	Corsa ammortizzo ant./post.		
32	12	M10x1.25	30	18.5	18	22	4	G1/8	26	119	5.5	145	5	27	16	M6	5	32.5	47	10	6	17	17		
40	16	M12x1.25	35	19	21	24	4	G1/4	30	130	5.5	160	5	30	16	M6	5	38	55	13	6	19	18		
50	20	M16x1.5	40	19.5	25	32	4	G1/4	37	131	6	168	6	30.5	16	M8	8	46.5	65	17	8	24	20		
63	20	M16x1.5	45	24	26	32	4	G3/8	37	146	6	183	6	37.5	16	M8	8	56.5	75	17	8	24	22		
80	25	M20x1.5	45	23.5	30	40	4	G3/8	46	153	0	199	7	37	19	M10	8	72	93	22	6	30	25		
100	25	M20x1.5	55	24	35	40	4	G1/2	51	163	0	214	7	39.5	19.5	M10	8	89	110	22	6	30	26		
125	32	M27x2	60	28	42	54	6	G1/2	65	185	6	250	8	44	23	M12	10.5	110	135	27	12	41	33		

Cilindri Serie 63 a profilo, semplice effetto, molla posteriore

Versioni: 63MP9... e 63LP9...



+ = sommare la corsa
++ = sommare la corsa due volte

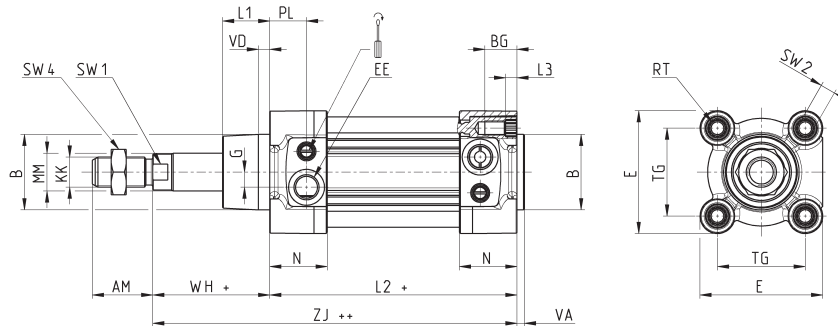

INGOMBRI																									
Ø	ØMM	KK	ØB	PL	L1	AM	VA	EE	WH	L2	L3	ZJ	VD	N	BG	RT	G	TG	E	SW1	SW2	SW4	Corsa ammortizzo ant./post.		
32	12	M10x1.25	30	18.5	18	22	4	G1/8	51	119	5.5	170	5	27	16	M6	5	32.5	47	10	6	17	17		
40	16	M12x1.25	35	19	21	24	4	G1/4	55	130	5.5	185	5	30	16	M6	5	38	55	13	6	19	18		
50	20	M16x1.5	40	19.5	25	32	4	G1/4	62	131	6	193	6	30.5	16	M8	8	46.5	65	17	8	24	20		
63	20	M16x1.5	45	24	26	32	4	G3/8	62	146	6	208	6	37.5	16	M8	8	56.5	75	17	8	24	22		
80	25	M20x1.5	45	23.5	30	40	4	G3/8	71	153	0	224	7	37	19	M10	8	72	93	22	6	30	25		
100	25	M20x1.5	55	24	35	40	4	G1/2	76	163	0	239	7	39.5	19.5	M10	8	89	110	22	6	30	26		
125	32	M27x2	60	28	42	54	6	G1/2	90	185	6	275	8	44	23	M12	10.5	110	135	27	12	41	33		

Cilindri Serie 63 a tubo tondo, semplice effetto, molla anteriore

Versioni: 63MT1... e 63LT1...

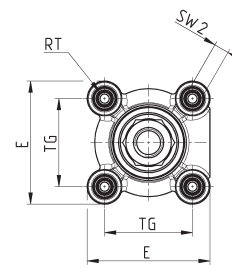
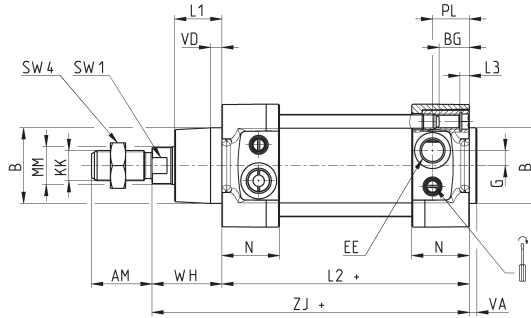

Ø32-40-50-63-125



Ø80-100

+ = sommare la corsa

Nota tabella:
* = chiave speciale
80-62/8C
(vedi accessori)

CILINDRI SERIE 63

INGOMBRI																							
Ø	ØMM	KK	ØB	PL	L1	AM	VA	EE	WH	L2	L3	ZJ	VD	N	BG	RT	G	TG	E	SW1	SW2	SW4	Corsa ammortizzo ant./post.
32	12	M10x1.25	30	18.5	18	22	4	G1/8	26	119	5	145	5	27	16	M6	5	32.5	47	10	6	17	17
40	16	M12x1.25	35	19	21	24	4	G1/4	30	130	5	160	5	30	16	M6	5	38	55	13	6	19	18
50	20	M16x1.5	40	19.5	25	32	4	G1/4	37	131	5	168	6	30.5	16	M8	8	46.5	65	17	8	24	20
63	20	M16x1.5	45	24	26	32	4	G3/8	37	146	5	183	6	37.5	16	M8	8	56.5	75	17	8	24	22
80	25	M20x1.5	45	23.5	30	40	4	G3/8	46	153	0	199	7	37	19	M10	8	72	93	22	*	30	25
100	25	M20x1.5	55	24	35	40	4	G1/2	51	163	0	214	7	39.5	19.5	M10	8	89	110	22	*	30	26
125	32	M27x2	60	28	42	54	6	G1/2	65	185	6	250	8	44	23	M12	10.5	110	135	27	12	41	33

Cilindri Serie 63 a tubo tondo, semplice effetto, molla posteriore

Versioni: 63MT9... e 63LT9...

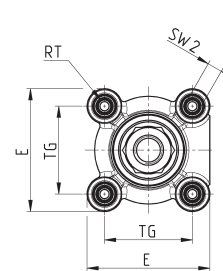
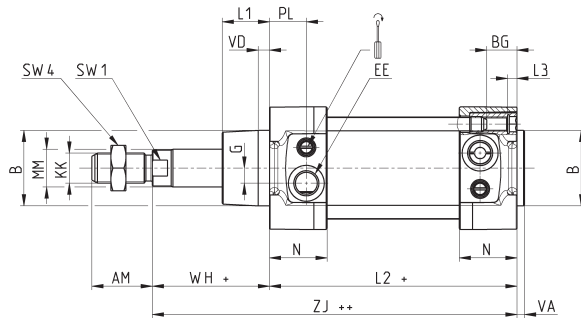

Ø32-40-50-63-125



Ø80-100

+ = sommare la corsa

Nota tabella:
* = chiave speciale
80-62/8C
(vedi accessori)

INGOMBRI																							
Ø	ØMM	KK	ØB	PL	L1	AM	VA	EE	WH	L2	L3	ZJ	VD	N	BG	RT	G	TG	E	SW1	SW2	SW4	Corsa ammortizzo ant./post.
32	12	M10x1.25	30	18.5	18	22	4	G1/8	51	119	5	170	5	27	16	M6	5	32.5	47	10	6	17	17
40	16	M12x1.25	35	19	21	24	4	G1/4	55	130	5	185	5	30	16	M6	5	38	55	13	6	19	18
50	20	M16x1.5	40	19.5	25	32	4	G1/4	62	131	5	193	6	30.5	16	M8	8	46.5	65	17	8	24	20
63	20	M16x1.5	45	24	26	32	4	G3/8	62	146	5	208	6	37.5	16	M8	8	56.5	75	17	8	24	22
80	25	M20x1.5	45	23.5	30	40	4	G3/8	71	153	0	224	7	37	19	M10	8	72	93	22	*	30	25
100	25	M20x1.5	55	24	35	40	4	G1/2	76	163	0	239	7	39.5	19.5	M10	8	89	110	22	*	30	26
125	32	M27x2	60	28	42	54	6	G1/2	90	185	6	275	8	44	23	M12	10.5	110	135	27	12	41	33

Cilindri Serie 63 a profilo, stelo passante

Versioni: 63MP6..., 63MP7..., 63LP6... e 63LP7...
 Per i cilindri semplice effetto le quote L2 e ZM vanno aumentate di 25mm.



+ = sommare la corsa
 ++ = sommare la corsa due volte

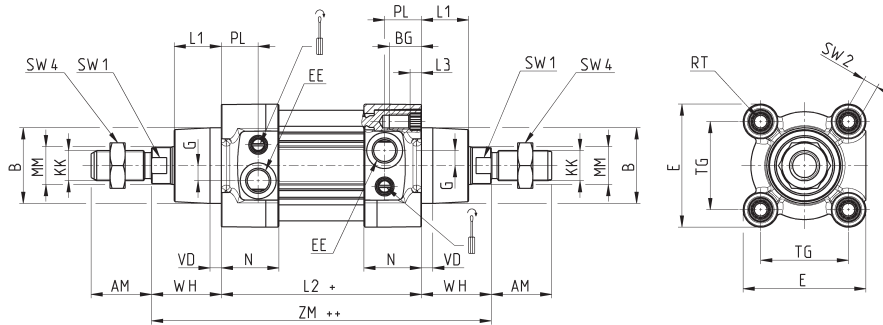

INGOMBRI																							
Ø	ØMM	KK	ØB	PL	L1	AM	EE	WH	L2	L3	ZM	VD	N	BG	RT	G	TG	E	ØF	SW1	SW2	SW4	Corsa ammortizzo ant./post.
32	12	M10x1.25	30	18.5	18	22	G1/8	26	94	5.5	146	5	27	16	M6	5	32.5	47	-	10	6	17	17
40	16	M12x1.25	35	19	21	24	G1/4	30	105	5.5	165	5	30	16	M6	5	38	55	-	13	6	19	18
50	20	M16x1.5	40	19.5	25	32	G1/4	37	106	6	180	6	30.5	16	M8	8	46.5	65	8	17	8	24	20
63	20	M16x1.5	45	24	26	32	G3/8	37	121	6	195	6	37.5	16	M8	8	56.5	75	8	17	8	24	22
80	25	M20x1.5	45	23.5	30	40	G3/8	46	128	0	220	7	37	19	M10	8	72	93	8	22	6	30	25
100	25	M20x1.5	55	24	35	40	G1/2	51	138	0	240	7	39.5	19.5	M10	8	89	110	8	22	6	30	26
125	32	M27x2	60	28	42	54	G1/2	65	160	6	290	8	44	23	M12	10.5	110	135	-	27	12	41	33

Cilindri Serie 63 a tubo tondo, stelo passante

Versioni: 63MT6..., 63MT7..., 63LT6... e 63LT7...
 Per i cilindri semplice effetto le quote L2 e ZM vanno aumentate di 25mm



+ = sommare la corsa
 ++ = sommare la corsa due volte

Nota tabella:
 * = chiave speciale 80-62/8C (vedi accessori)

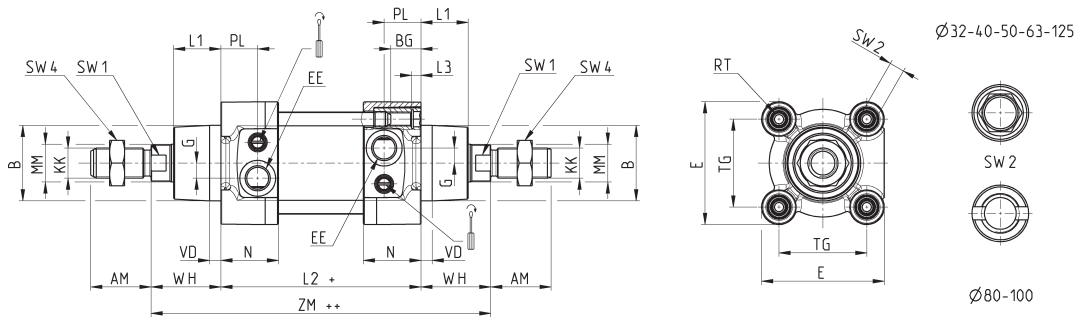

INGOMBRI																							
Ø	ØMM	KK	ØB	PL	L1	AM	EE	WH	L2	L3	ZM	VD	N	BG	RT	G	TG	E	ØF	SW1	SW2	SW4	Corsa ammortizzo ant./post.
32	12	M10x1.25	30	18.5	18	22	G1/8	26	94	5	146	5	27	16	M6	5	32.5	47	-	10	6	17	17
40	16	M12x1.25	35	19	21	24	G1/4	30	105	5	165	5	30	16	M6	5	38	55	-	13	6	19	18
50	20	M16x1.5	40	19.5	25	32	G1/4	37	106	6	180	6	30.5	16	M8	8	46.5	65	8	17	8	24	20
63	20	M16x1.5	45	24	26	32	G3/8	37	121	5	195	6	37.5	16	M8	8	56.5	75	8	17	8	24	22
80	25	M20x1.5	45	23.5	30	40	G3/8	46	128	0	220	7	37	19	M10	8	72	93	8	22	*	30	25
100	25	M20x1.5	55	24	35	40	G1/2	51	138	0	240	7	39.5	19.5	M10	8	89	110	8	22	*	30	26
125	32	M27x2	60	28	42	54	G1/2	65	160	6	290	8	44	23	M12	10.5	110	135	-	27	12	41	33

Cilindri Serie 63 con bloccastelo

Versioni: 63MT1... and 63LT1...

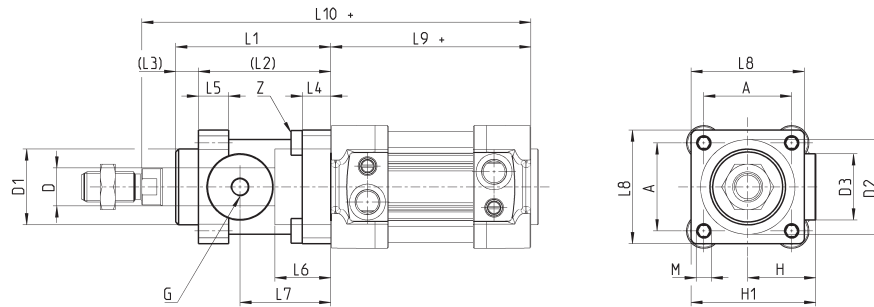

+ = aggiungere la corsa

CILINDRI SERIE 63

Ø	øD	øD1	øD2	øD3	A	G	H	H1	L1	L2	L3	L4	L5	L6	L7	L8	L9+	L10+	M	Z
32	12	30.5	35	25	32.5	M5	25.5	46.5	58	48	10	8	13	20.5	34	45	94	160	M6	M6X20
40	16	35	40	28	38	G1/8	30	53	65	55	10	8	13	22.5	38	50	105	178	M6	M6X20
50	20	40	50	35	46.5	G1/8	36	64	82	70	12	15	16	29.5	48	60	106	200	M8	M6X20
63	20	45	60	38	56.5	G1/8	40	75	82	70	12	15	16	29.5	49.5	70	121	215	M8	M8X30
80	25	45	80	48	72	G1/8	50	95	110	90	20	18	20	35	61	90	128	254	M10	M10X35
100	25	55	100	58	89	G1/8	58	110.5	115	100	15	18	20	39	69	105	138	269	M10	M10X35
125	32	60	130	65	110	G1/8	80	150	167	122	45	22	30	51	86.5	140	160	350	M12	M12X40

Cilindri Serie 63 con filetto stelo femmina

Nuova versione

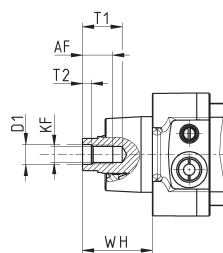

Ø	AF Min	KF	D1 Ø	T1 Max	T2	WH
32	12	M6X1	6.4	16	2.6	26
40	12	M8X1.25	8.4	16	3.3	30
50	16	M10X1.5	10.5	21	4.7	37
63	16	M10X1.5	10.5	21	4.7	37
80	20	M12X1.75	13	26.5	6.1	46
100	20	M12X1.75	13	26.5	6.1	54
125	32	M16X2	17	40	8	65

Cilindri Serie 63 a tubo tondo, versione tandem

Nuova versione

+ = sommare la corsa
++ = sommare la corsa
due volte

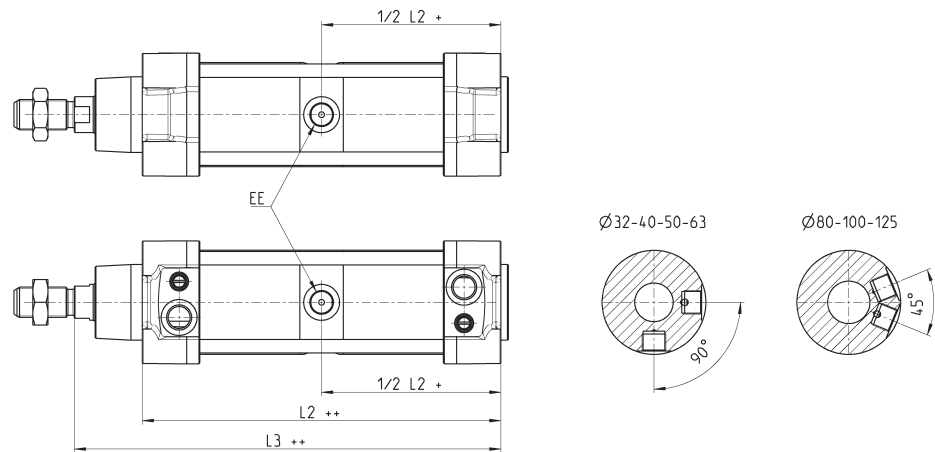

Ø	EE	L2	L3
32	G1/8	171.5	197.5
40	G1/4	191.5	221.5
50	G1/4	188	225
63	G3/8	204	241
80	G3/8	225.5	271.5
100	G1/2	231	282
125	G1/2	264	329

CILINDRI SERIE 63

Cilindri Serie 63 a profilo, versione tandem

Nuova versione

+ = sommare la corsa
++ = sommare la corsa
due volte

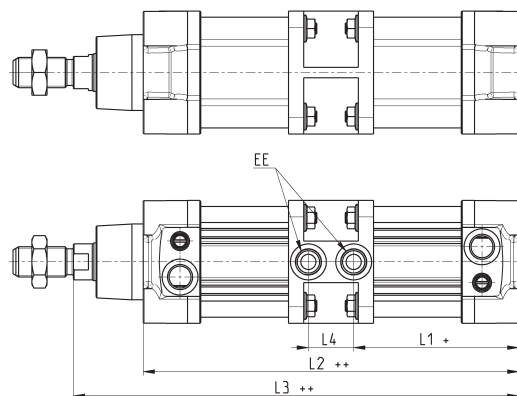

Ø	EE	L1	L2	L3	L4
32	G1/8	76.5	171.5	197.5	18.5
40	G1/4	88.5	200	230	23
50	G1/4	87.5	199	236	24
63	G3/8	98	223	260	27
80	G3/8	104.5	236	282	27
100	G1/2	116	260	311	28
125	G1/2	132	264	329	0

Cilindri Serie 63 a tubo tondo, versione più posizioni

Nuova versione

X1 = corsa parziale
X2 = corsa totale

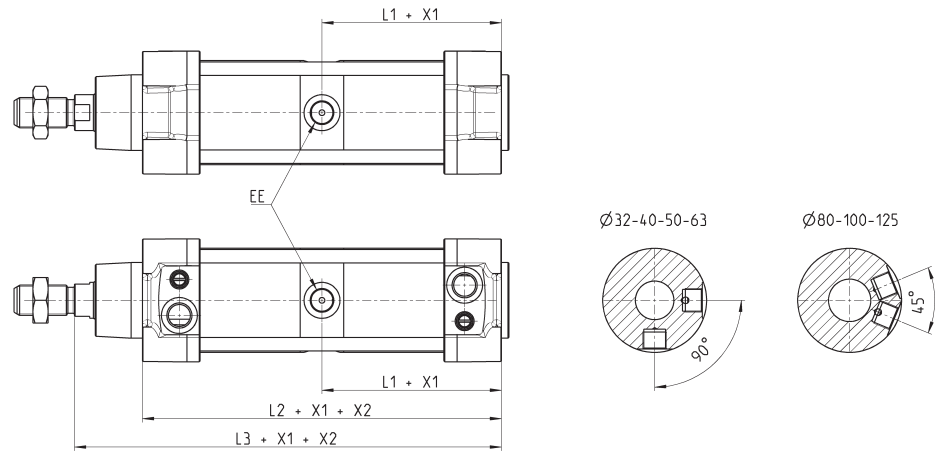

Ø	EE	L1	L2	L3
32	G1/8	86	171.5	197.5
40	G1/4	96	191.5	221.5
50	G1/4	94	188	225
63	G3/8	102	204	241
80	G3/8	113	225.5	271.5
100	G1/2	115.5	231	282
125	G1/2	132	264	329

Cilindri Serie 63 a profilo, versione più posizioni

Nuova versione

X1 = corsa parziale
X2 = corsa totale

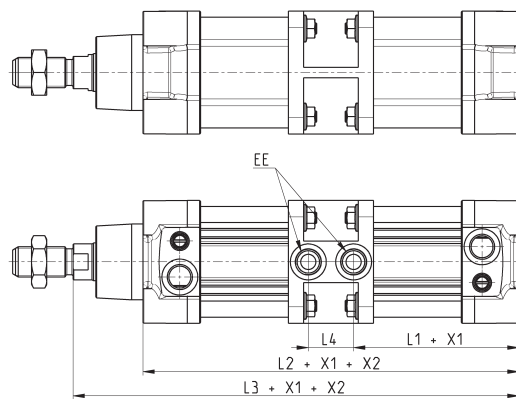

Ø	EE	L1	L2	L3	L4
32	G1/8	76.5	171.5	197.5	18.5
40	G1/4	88.5	200	230	23
50	G1/4	87.5	199	236	24
63	G3/8	98	223	260	27
80	G3/8	104.5	236	282	27
100	G1/2	116	260	311	28
125	G1/2	132	264	329	0

Cilindri Serie 63 con protezione a soffietto

Nuova versione

+ = sommare la corsa
 ++ = sommare la corsa
 due volte

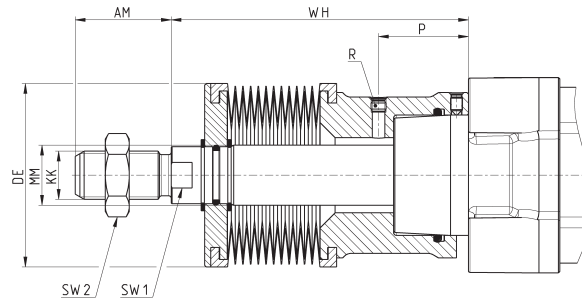

Ø	Corsa	WH	AM	KK	MM	P	R	SW1	SW2
32	0 ÷ 245	88	22	M10X1.25	12	25	M5	10	17
32	246 ÷ 490	132	22	M10X1.25	12	25	M5	10	17
40	0 ÷ 245	89	24	M12X1.25	16	26	M5	13	19
40	246 ÷ 490	133	24	M12X1.25	16	26	M5	13	19
50	0 ÷ 245	99	32	M16X1.5	20	30	M5	17	24
50	246 ÷ 490	143	32	M16X1.5	20	30	M5	17	24
63	0 ÷ 245	76	32	M16X1.5	20	16.5	M5	17	24
63	246 ÷ 490	120	32	M16X1.5	20	16.5	M5	17	24
80	0 ÷ 285	86	40	M20X1.5	25	11.5	G1/8	22	30
80	286 ÷ 570	139	40	M20X1.5	25	11.5	G1/8	22	30
100	0 ÷ 285	86	40	M20X1.5	25	12	G1/8	22	30
100	286 ÷ 570	139	40	M20X1.5	25	12	G1/8	22	30
125	0 ÷ 285	108	54	M27X2	32	30	G1/8	29	41
125	286 ÷ 570	161	54	M27X2	32	30	G1/8	29	41

Cilindri Serie 63 a tubo tondo, back to back (TR)

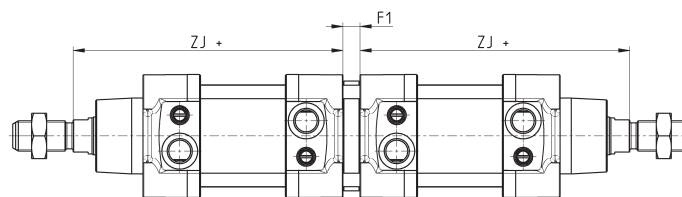
Nuova versione

Ø	F1	ZJ+	corsa max totale (mm)
32	9	120	500
40	9	135	800
50	9	143	800
63	9	158	700
80	9	174	1000
100	9	189	900
125	20	225	1000

Accessorio per contrapposti Mod. DC-63



Materiale: Alluminio

La fornitura comprende:
N° 1 flangia
N° 8 grani
N° 8 dadi

+ = sommare la corsa

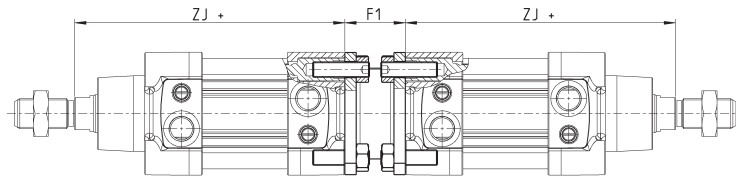

Mod.	∅	F1	ZJ+	peso (g)	corsa max totale (mm)	coppia di serraggio
DC-63-32	32	27	120	130	500	5 Nm
DC-63-40	40	27	135	160	800	5 Nm
DC-63-50	50	32	143	285	800	10 Nm
DC-63-63	63	28	158	340	700	10 Nm
DC-63-80	80	38	174	670	1000	15 Nm
DC-63-100	100	38	189	820	900	15 Nm
DC-63-125	125	48	225	1300	1000	20 Nm

Ancoraggio a piedini Mod. B-41



Materiale: Acciaio zincato

La fornitura comprende:
N° 2 piedini
N° 4 viti

+ = sommare la corsa

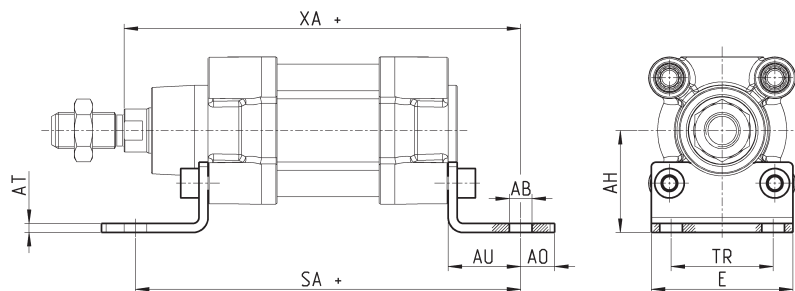

Mod.	∅	AT	SA+	XA+	TR	E	AB	AH	AO	AU	coppia di serraggio
B-41-32	32	4	142	144	32	45	7	32	11	24	5 Nm
B-41-40	40	4	161	163	36	53,5	10	36	15	28	5 Nm
B-41-50	50	4	170	175	45	62,5	10	45	15	32	10 Nm
B-41-63	63	5	185	190	50	73	10	50	15	32	10 Nm
B-41-80	80	6	210	216	63	92	12	63	20	41	15 Nm
B-41-100	100	6	220	230	75	108,5	14,5	71	25	41	15 Nm
B-41-125	125	7	250	270	90	132	16,5	90	25	45	20 Nm

Ancoraggio a flangia anteriore e posteriore Mod. D-E

Materiale: Alluminio

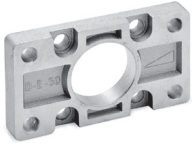

La fornitura comprende:
N° 1 flangia
N° 4 viti

+ = sommare la corsa

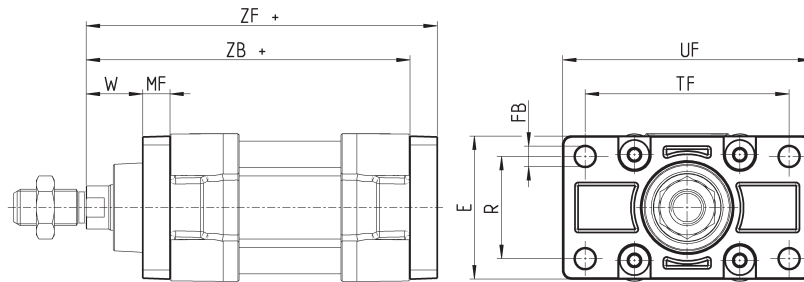

Mod.	∅	W	MF	ZB+	TF	R	UF	E	FB	ZF+	coppia di serraggio
D-E-41-32	32	16	10	120	64	32	86	45	7	130	5 Nm
D-E-41-40	40	20	10	135	72	36	88	52	9	145	5 Nm
D-E-41-50	50	25	12	143	90	45	110	63	9	155	10 Nm
D-E-41-63	63	25	12	158	100	50	116	73	9	170	10 Nm
D-E-41-80	80	30	16	174	126	63	148	95	12	190	15 Nm
D-E-41-100	100	35	16	189	150	75	176	115	14	205	15 Nm
D-E-41-125	125	45	20	225	180	90	224	135	16	245	20 Nm

Ancoraggio a cerniera femmina posteriore Mod. C e C-H

Materiale: Alluminio

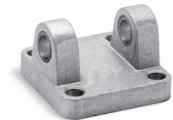

La fornitura comprende:
N° 1 cerniera femmina
N° 4 viti

+ = sommare la corsa

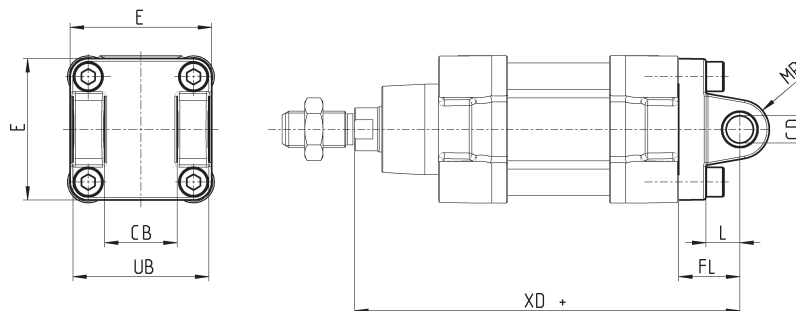

Mod.	∅	CD	L	FL	XD+	MR	E	CB	UB	coppia di serraggio
C-41-32	32	10	12	22	142	10	45	26	45	5 Nm
C-41-40	40	12	15	25	160	12	53.5	28	52	5 Nm
C-41-50	50	12	15	27	170	13	62.5	32	60	10 Nm
C-H-41-63	63	16	20	32	190	17	73	40	70	10 Nm
C-H-41-80	80	16	24	36	210	17	92	50	90	15 Nm
C-H-41-100	100	20	29	41	230	21	108.5	60	110	15 Nm
C-H-41-125	125	25	30	50	275	26	132	70	130	20 Nm

Ancoraggio a cerniera femmina anteriore Mod. H e C-H

Materiale: Alluminio

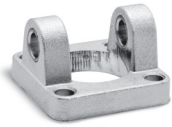

La fornitura comprende:
N° 1 cerniera femmina e
N° 4 viti

+ = sommare la corsa

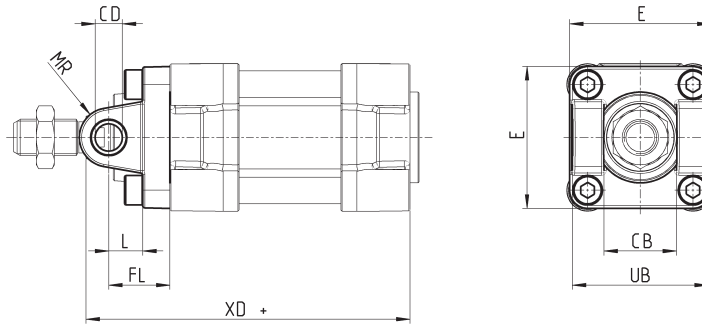

Mod.	∅	CB	UB	E	XD	FL	L	CD	MR	coppia di serraggio
H-41-32	32	26	45	45	120	22	12	10	10	5 Nm
H-41-40	40	28	52	53.5	135	25	15	12	12	5 Nm
H-41-50	50	32	60	62.5	143	27	15	12	13	10 Nm
H-60-63	63	40	70	73	158	32	20	16	17	10 Nm
C-H-41-80	80	50	90	92	174	36	24	16	17	15 Nm
C-H-41-100	100	60	110	108.5	189	41	29	20	21	15 Nm
C-H-41-125	125	70	130	132	225	50	30	25	26	20 Nm

Ancoraggio a cerniera maschio posteriore Mod. L

Materiale: Alluminio

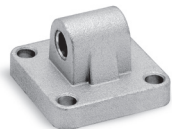

La fornitura comprende:
N° 1 cerniera maschio e N°
4 viti

+ = sommare la corsa

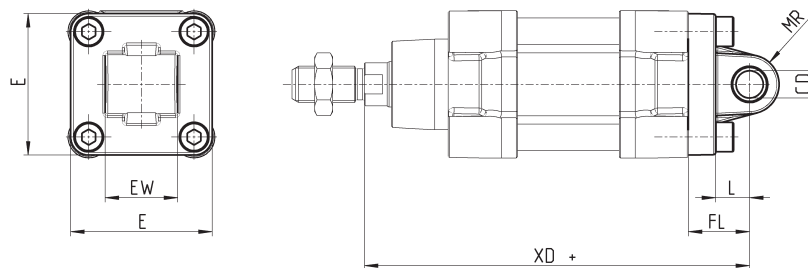

INGOMBRI										
Mod.	∅	CD	L	FL	XD+	MR	E	EW	Coppia di serraggio	
L-41-32	32	10	12	22	142	10	45	26	5 Nm	
L-41-40	40	12	15	25	160	13	53.5	28	5 Nm	
L-41-50	50	12	15	27	170	13	62.5	32	10 Nm	
L-41-63	63	16	20	32	190	17	73	40	10 Nm	
L-41-80	80	16	24	36	210	17	92	50	15 Nm	
L-41-100	100	20	29	41	230	21	108.5	60	15 Nm	
L-41-125	125	25	30	50	275	26	132	70	20 Nm	

Ancoraggio a cerniera anteriore/posteriore lamata Mod. FN

Materiale: acciaio zincato

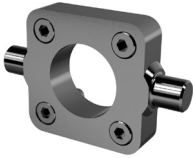

La fornitura comprende:
N° 1 cerniera intermedia
lamata
N° 4 viti

+ = sommare la corsa

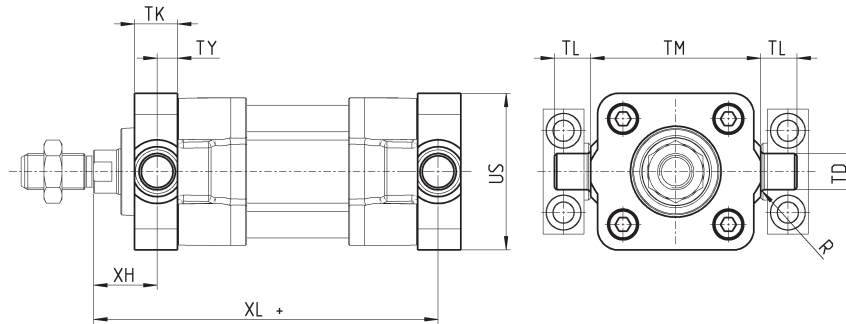

INGOMBRI											
Mod.	∅	TK	TY	XH	XL	US	TL	TM	TD	R	coppia di serraggio
FN-32	32	14	6.5	19.5	126.5	46	12	50	12	1	5 Nm
FN-40	40	19	9	21	144	59	16	63	16	1.5	5 Nm
FN-50	50	19	9	28	152	69	16	75	16	1.6	10 Nm
FN-63	63	24	11.5	25.5	169.5	84	20	90	20	1.6	10 Nm
FN-80	80	24	11.5	34.5	185.5	102	20	110	20	1.6	15 Nm
FN-100	100	29	14	37	203	125	25	132	25	2	15 Nm
FN-125	125	30	15	50	240	150	25	160	25	2	20 Nm

Ancoraggio a cerniera con snodo sferico Mod. R

* Ancoraggio non a norma ISO 15552
Materiale: Alluminio

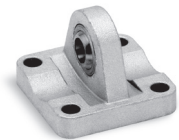

La fornitura comprende:
N° 1 cerniera snodata
N° 4 viti

+ = sommare la corsa

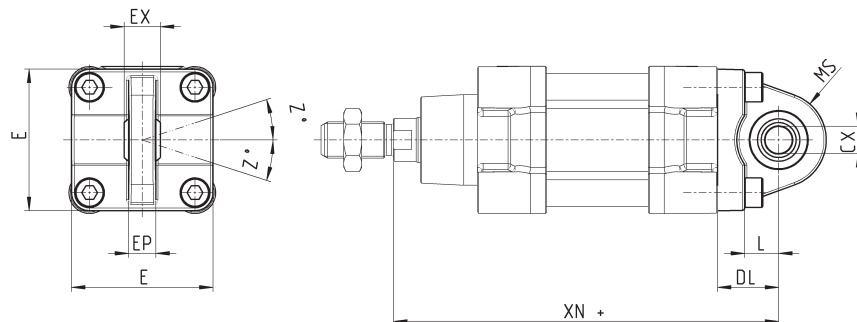

Mod.	∅	∅CX	L	DL	XN+	MS	E	EX	EP	Z	Coppia di serraggio
R-41-32	32	10	12	22	142	18	45	14	10.5	4	5 Nm
R-41-40	40	12	15	25	160	18	53.5	16	12	4	5 Nm
R-41-50	50	12*	15	27	170	21	62.5	16*	12*	4	10 Nm
R-41-63	63	16	20	32	190	23	73	21	15	4	10 Nm
R-41-80	80	16*	24	36	210	28	92	21*	15*	4	15 Nm
R-41-100	100	20	29	41	230	30	108.5	25	18	4	15 Nm
R-41-125	125	30	30	50	275	40	140	37	25	4	20 Nm

Ancoraggio a cerniera intermedia Mod. F per cil. a tubo tondo



Materiale: acciaio zincato

La fornitura comprende:
N° 1 cerniera intermedia
N° 8 grani

+ = sommare la corsa

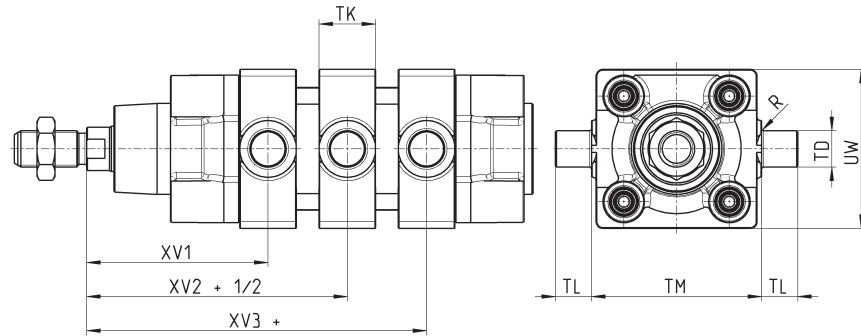

INGOMBRI										
Mod.	∅	XV1	XV2	XV3	TM (h14)	TK	TD (e9)	TL	UW	R
F-32	32	62	73	84	50	20	12	12	50	0.5
F-40	40	69	82,5	96	63	20	16	16	60	1
F-50	50	79	90	101	75	25	16	16	70	1
F-63	63	86	97,5	109	90	25	20	20	85	1
F-80	80	97	110	123	110	30	20	20	105	1
F-100	100	104,5	120	135,5	132	30	25	25	125	1.5
F-125	125	123	145	167	160	30	25	25	155	1.5

Ancoraggio a cerniera intermedia Mod. F-63 per cil. a profilo



Materiale: acciaio zincato

La fornitura comprende:
N° 1 cerniera intermedia
N° 8 grani
N° 2 viti di fissaggio

+ = sommare la corsa

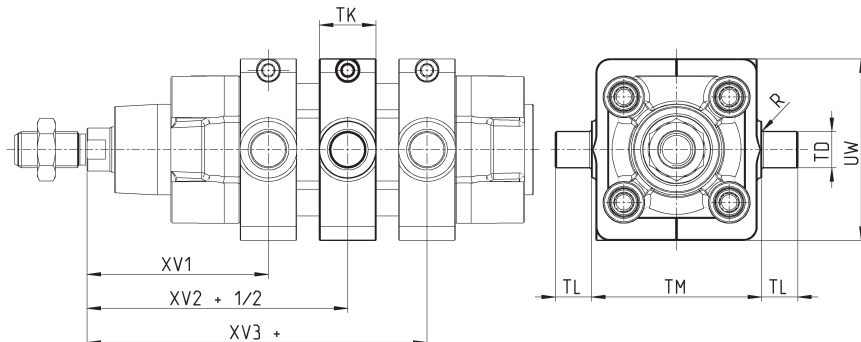

INGOMBRI										
Mod.	∅	XV1	XV2	XV3	TM	TK	TD	TL	UW	R
F-63-32	32	63	73	83	50	20	12	12	62	0.5
F-63-40	40	70	82.5	95	61	20	16	16	70	1
F-63-50	50	80	90	100	71	25	16	16	91	1
F-63-63	63	87	97.5	108	84	25	20	20	90	1
F-63-80	80	98	110	122	106	30	20	20	115	1
F-63-100	100	105.5	120	134.5	128	30	25	25	135	1.5
F-63-125	125	124	145	166	156	30	25	25	162	1.5

Combinazione di accessori Mod. C+L+S

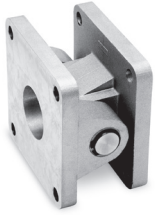

Materiale: Alluminio

+ = sommare la corsa

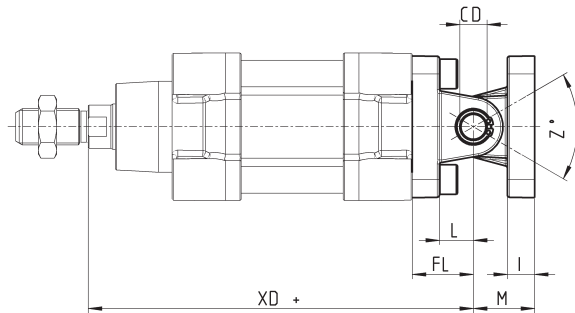
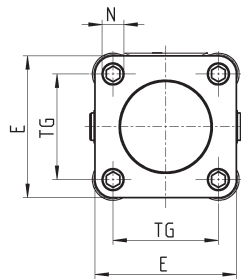

INGOMBRI												
Mod.	∅	E	TG	_g N	XD+	_g CD	L	FL	I	M	Z° (max)	coppia di serraggio
C+L+S	32	45	32.5	6.5	142	10	12	22	10	22	30	5 Nm
C+L+S	40	53.5	38	6.5	160	12	15	25	10	25	40	5 Nm
C+L+S	50	62.5	46.5	9	170	12	15	27	12	27	25	10 Nm
C+L+S	63	73	56.5	9	190	16	20	32	12	32	36	10 Nm
C+L+S	80	92	72	11	210	16	24	36	12	36	34	15 Nm
C+L+S	100	108.5	89	11	230	20	29	41	12	41	38	15 Nm
C+L+S	125	132	110	13	275	25	30	50	25	50	30	20 Nm

Supporto 90° per cerniera femmina Mod. ZC

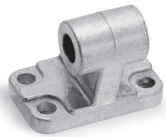

CETOP RP 107P
Materiale: Alluminio

La fornitura comprende :
N°1 supporto maschio

+ = sommare la corsa

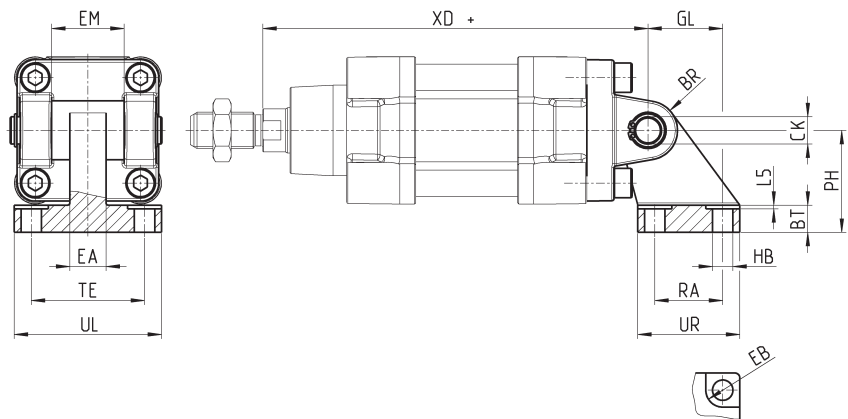

INGOMBRI																
Mod.	∅	EB	CK	HB	XD+	TE	UL	EA	GL	L5	RA	EM	UR	PH	BT	BR
ZC-32	32	11	10	6,6	142	38	51	10	21	1,6	18	26	31	32	8	10
ZC-40	40	11	12	6,6	160	41	54	15	24	1,6	22	28	35	36	10	11
ZC-50	50	15	12	9	170	50	65	16	33	1,6	30	32	45	45	12	13
ZC-63	63	15	16	9	190	52	67	16	37	1,6	35	40	50	50	14	15
ZC-80	80	18	16	11	210	66	86	20	47	2,5	40	50	60	63	14	15
ZC-100	100	18	20	11	230	76	96	20	55	2,5	50	60	70	71	17	19
ZC-125	125	20	25	14	275	94	124	30	70	3,2	60	70	90	90	20	22,5

Supporto per cerniera intermedia Mod. BF

Materiale: Alluminio

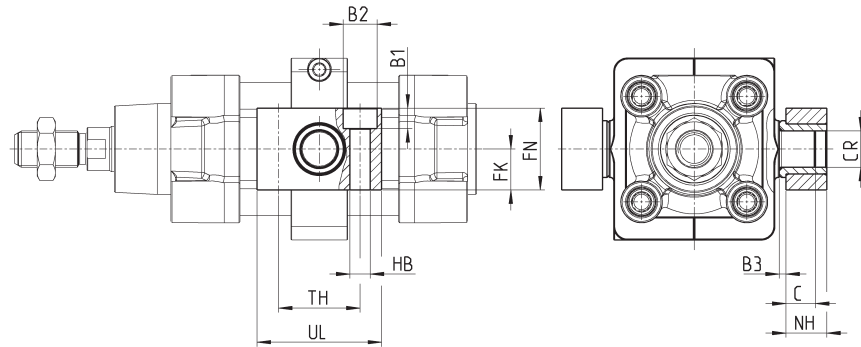
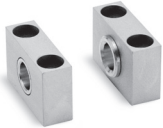

La fornitura comprende:
N° 2 supporti

CILINDRI SERIE 63

Mod.	∅	∅CR	NH	C	B3	TH	UL	FK	FN	B1	B2	HB
BF-32	32	12	15	7,5	3	32	46	15	30	6,8	11	6,6
BF-40-50	40 - 50	16	18	9	3	36	55	18	36	9	15	9
BF-63-80	63 - 80	20	20	10	3	42	65	20	40	11	18	11
BF-100-125	100 - 125	25	25	12,5	3,5	50	75	25	50	13	20	14

Accessorio per il montaggio delle valvole sul cilindro

Le piastre di collegamento Mod. PCV permettono di collegare le valvole o le elettrovalvole direttamente sul cilindro, formando così una unità compatta da applicare.

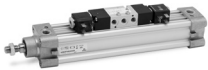

Verificare che la dimensione WW della valvola da fissare sia minore della dimensione JJ del cilindro scelto. Ulteriori informazioni su <http://catalogue.camozzi.com/downloads>.

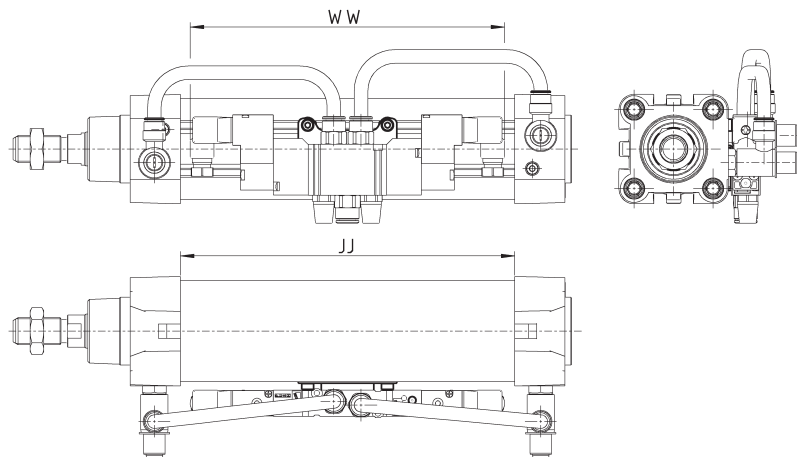

Mod.	
PCV-62-K3	per fissare valvole - elettrovalvole Serie 3
PCV-62-K4	per fissare valvole - elettrovalvole Serie 4 attacco G1/4
PCV-62-KEN	per fissare valvole - elettrovalvole Serie EN
PCV-62-K8	per fissare valvole - elettrovalvole Serie 4 attacco G1/8 e Serie 3 attacco G1/4

Spinotto Mod. S



La fornitura comprende:
N° 1 spinotto in acciaio INOX 303
N° 2 seeger in acciaio

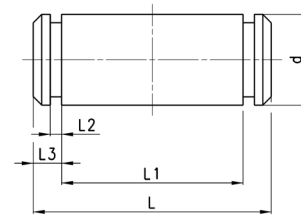

INGOMBRI							
Mod.	∅	d	L	L1	L2	L3	Materiale
S-32	32	10	52	46	1.1	3	
S-40	40	12	59	53	1.1	3	
S-50	50	12	67	61	1.1	3	
S-63	63	16	77	71	1.1	3	
S-80	80	16	97	91	1.1	3	
S-100	100	20	121	111	1.3	5	
S-125	125	25	140.5	132	1.3	4.25	

Snodo sferico Mod. GA



ISO 8139
Materiale: Acciaio zincato

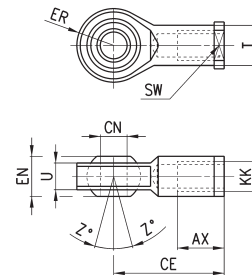

Mod.	∅ ⁽¹⁷⁾	U	EN	ER	AX	CE	KK	∅ ⁽¹⁷⁾ T	Z	SW
GA-32	10	10,5	14	14	20	43	M10X1,25	15	6,5	17
GA-40	12	12	16	16	22	50	M12X1,25	17,5	6,5	19
GA-50-63	16	15	21	21	28	64	M16X1,5	22	7,5	22
GA-80-100	20	18	25	25	33	77	M20x1,5	27,5	7	30
GA-41-125	30	25	37	37	51	110	M27x2	40	7,5	41

Snodo sferico maschio Mod. GY



Materiale: Zama e Acciaio zincato

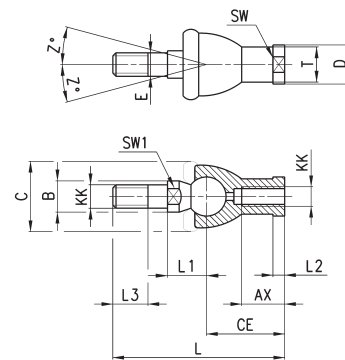

INGOMBRI																
Mod.	∅	KK	L	CE	L2	AX	SW	SW1	L1	L3	∅ ⁽¹⁷⁾ T	∅ ⁽¹⁷⁾ D	E	∅ ⁽¹⁷⁾ B	∅ ⁽¹⁷⁾ C	Z
GY-32	32	M10X1,25	74	35	6,5	18	17	11	19,5	15	15	19	10	14	28	15
GY-40	40	M12X1,25	84	40	6,5	20	19	17	21	17	17,5	22	12	19	32	15
GY-50-63	50-63	M16X1,5	112	50	8	27	22	19	27,5	23	22	27	16	22	40	11
GY-80-100	80-100	M20x1,5	133	63	10	38	30	24	31,5	25	27,5	34	20	27	45	7,5

Forcella Mod. G

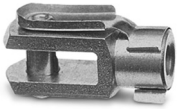

ISO 8140
Materiale: Acciaio zincato

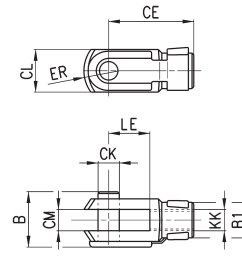

Mod.	ø _{CK}	LE	CM	CL	ER	CE	KK	B	ø _{B1}
G-25-32	10	20	10	20	12	40	M10 X 1,25	26	18
G-40	12	24	12	24	14	48	M12 X 1,25	32	20
G-50-63	16	32	16	32	19	64	M16 X 1,5	40	26
G-80-100	20	40	20	40	25	80	M20 X 1,5	48	34
G-41-125	30	54	30	55	38	110	M27 X 2	74	48

Dado stelo Mod. U



UNI EN ISO 4035
Materiale: Acciaio zincato

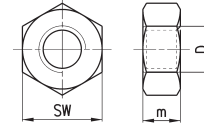

Mod.	D	m	SW
U-25-32	M10X1,25	6	17
U-40	M12X1,25	7	19
U-50-63	M16X1,5	8	24
U-80-100	M20x1,5	9	30
U-41-125	M27x2	12	41

Snodo autoallineante Mod. GK

Materiale: Acciaio zincato

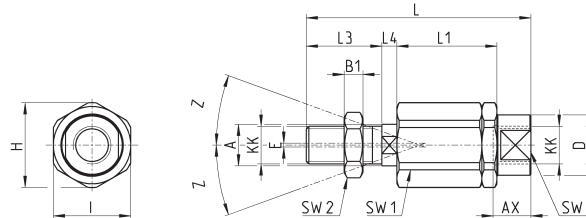

INGOMBRI																	
Mod.	ø	KK	L	L1	L3	L4	ø _A	ø _D	H	I	SW	SW1	SW2	B1	AX	Z	E
GK-25-32	25-32	M10x1,25	71,5	35	20	7,5	14	22	32	30	19	12	17	5	22	4	2
GK-40	40	M12x1,25	75,5	35	24	7,5	14	22	32	30	19	12	19	6	22	4	2
GK-50-63	50-63	M16x1,5	104	53	32	10	22	32	45	41	27	20	24	8	30	3	2
GK-80-100	80-100	M20x1,5	119	53	40	10	22	32	45	41	27	20	30	10	37	3	2
GK-125	125	M27x2	147	60	54	10	32	57	70	65	54	24	41	12	48	4	2

Giunto compensatore Mod. GKF

Materiale: Acciaio zincato

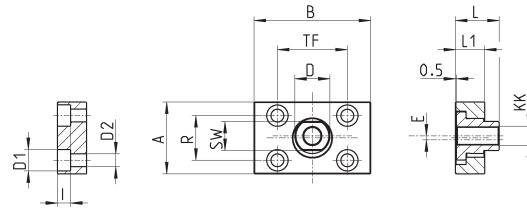

INGOMBRI														
Mod.	Ø	KK	A	B	R	TF	L	L1	I	Ø D	Ø D1	Ø D2	SW	E
GKF-25-32	32	M10x1,25	37	60	23	36	22,5	15	6,8	18	11	6,6	15	2
GKF-40	40	M12x1,25	56	60	38	42	22,5	15	9	20	15	9	15	2,5
GKF-50-63	50-63	M16x1,5	80	80	58	58	26,5	15	10,5	25	18	11	22	2,5
GKF-80-100	80-100	M20x1,5	90	90	65	65	32,5	20	13	30,5	20	14	27	2,5
GKF-125	125	M27x2	90	90	65	65	35,5	20	13	40	20	14	36	4

Chiave speciale per smontaggio cilindri Ø 80-100 a tubo tondo

Materiale: acciaio temprato

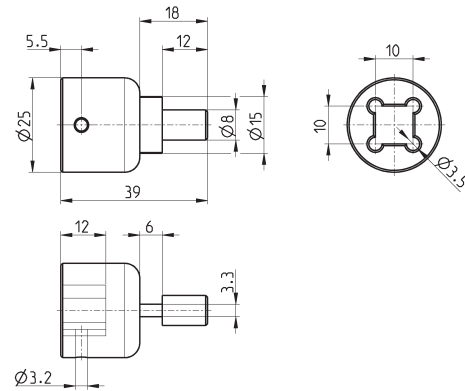
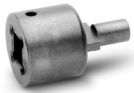

Mod.
80-62/8C