

Repair Parts Sheet	Revision	Revision Date	Product Code Beginning
Reference nr. L2804	Rev.B	08/2010	A - RC251 - RC252 - RC254
			B - RC256/8/10/12/14

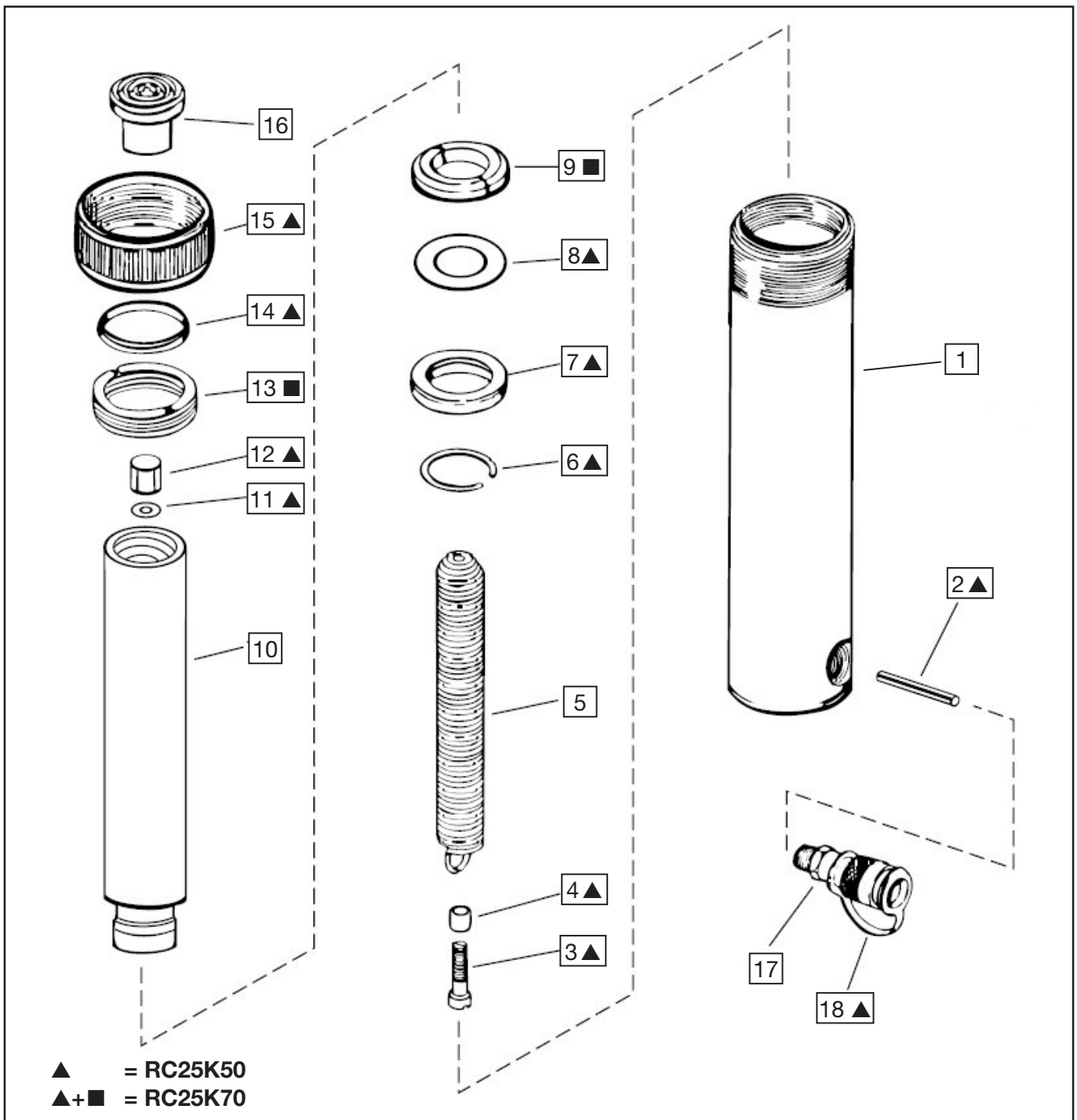

Repair Parts List

L 2804

Item nr.	Description	Qty.	RC251	RC252	RC254	RC256	RC258	RC2510	RC2512	RC2514
1	Base	1	Not available for services, order a new cylinder.							
2	Screw	1	▲	▲	▲					
2	Roll Pin	1				▲	▲	▲	▲	▲
3A	Self tapping screw	1	▲	▲	▲					
3B	Screw	1				▲	▲	▲	▲	▲
4	Bushing	1				▲	▲	▲	▲	▲
5	Spring (includes items 4,11&12)	1	L202110SR	L202110SR	CB425110SR	DD1188110SR	DD1187110SR	DD1186110SR	DD1185110SR	DD1184110SR
6	Retaining ring	1	▲	▲	▲	▲	▲	▲	▲	▲
7	U Cup	1	▲	▲	▲	▲	▲	▲	▲	▲
8	Washer	1	▲	▲	▲	▲	▲	▲	▲	▲
9	Rod Bearing	1	■	■	■	■	■	■	■	■
10	Plunger	1	Not available for services, order a new cylinder.							
11	Gasket	1	▲	▲	▲	▲	▲	▲	▲	▲
12	Nut	1	▲	▲	▲	▲	▲	▲	▲	▲
13	Stop ring	1	■	■	■	■	■	■	■	■
14	Wiper	1	▲	▲	▲	▲	▲	▲	▲	▲
15	Thread protector	1	▲	▲	▲	▲	▲	▲	▲	▲
16	Saddle	1	A252G	A252G	A252G	A252G	A252G	A252G	A252G	A252G
17	Coupler	1	CR400	CR400	CR400	CR400	CR400	CR400	CR400	CR400
18	Dust cap	1	▲	▲	▲	▲	▲	▲	▲	▲
19	Coupler O ring (not shown)	1	▲	▲	▲	▲	▲	▲	▲	▲
20	Enerpac decal (not shown)	1	▲	▲	▲	▲	▲	▲	▲	▲
21	Caution decal (not shown)	1	▲	▲	▲	▲	▲	▲	▲	▲
22	Saddle O ring (not shown)	1	▲	▲	▲	▲	▲	▲	▲	▲

▲ = Indicates items included in and only available as part of repair kit RC25K50.

■ = Indicates items included in and only available as part of repair kit RC25K70. RC25K70 includes 1x RC25K50.



Item nr.	Model	Torque / Remarks
3A	RC251 up to RC254	5.4 - 6.8 Nm 4 - 5 ft lbs
3B	RC256 up to RC2514	Firmly tighten screw to assure contact with the plunger
8	RC256 up to RC2514	Washer to be placed with sharp edge towards U Cup
12	all models	11 - 14 Nm 8 - 10 ft lbs
13	all models	7.9 - 10.2 Nm 70 - 90 in lbs secure with Loctite 222
17	all models	34 - 81 Nm 25 - 60 ft lbs
17	all models	Use Loctite 545 or teflon tape



**To maintain your warranty
Have your products inspected and repaired
by an authorised Enerpac Service Centre**

www.enerpac.com