



# CH 04 - PRESTAZIONI CON MOTORI A 4 POLI 1400 GIRI ENTRATA

TIPO	i=ratio	n2 r/min	Kw=P1	Nm=T2	f.s.	Pred. attacco motore possibili	
CH 04	7	200	0.55*	22	1.4	71/63	B5/B14
	10	140	0.55*	30	1.0	71/63	B5/B14
	14	100	0.37	29	1.0	71/63	B5/B14
	20	70	0.37	38	1.0	71/63	B5/B14
	28	50	0.37	40	0.9	71/63	B5/B14
	35	40	0.25	41	0.9	71/63	B5/B14
	46	30	0.18	37	1.0	63	B5/B14
	60	23	0.18	37	0.9	63	B5/B14
	70	20	0.12	33	0.9	63	B5/B14
	100	14	0.12	30	0.9	63	B5/B14

\* Motori gr. 71

Peso Kg 2,1

## DIMENSIONI

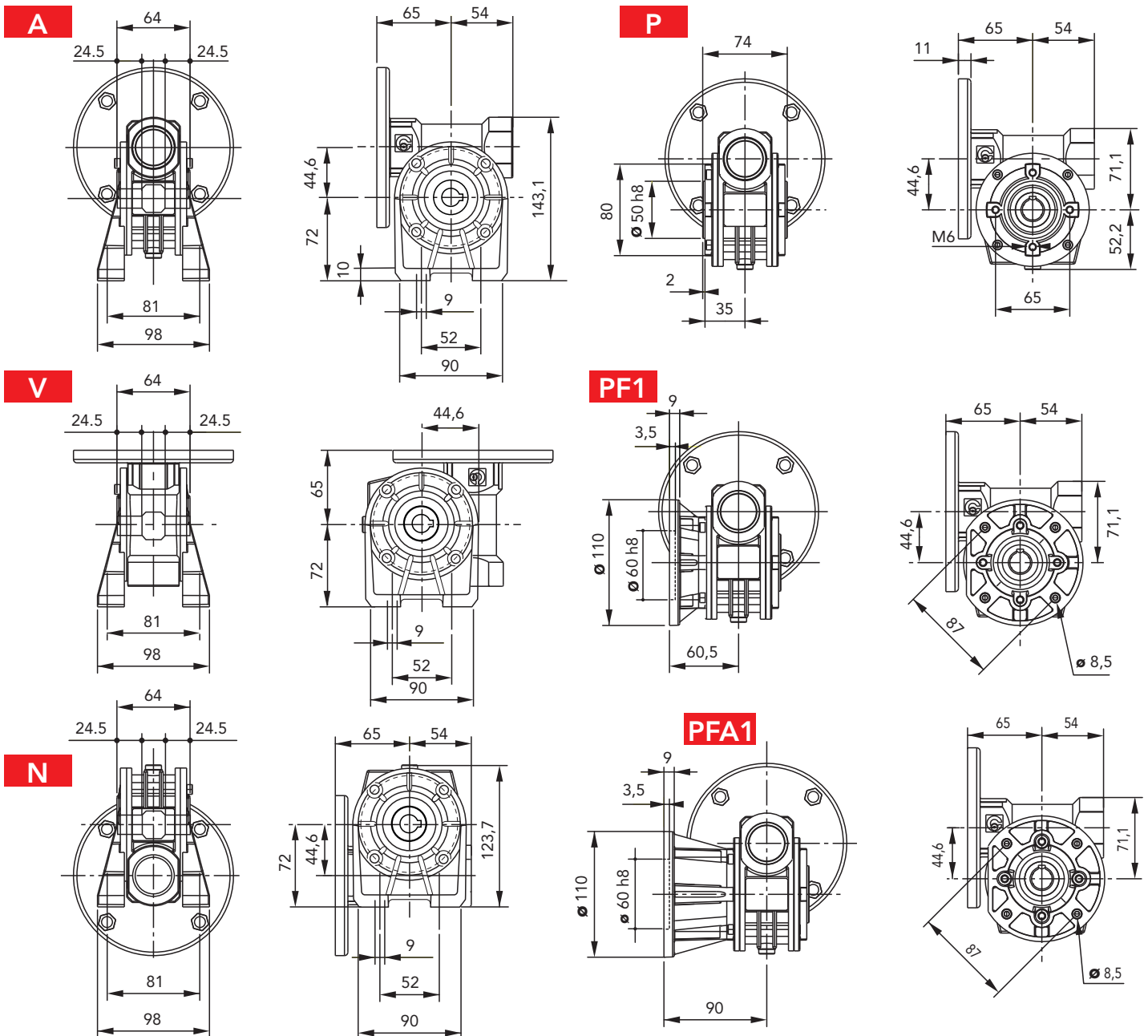



# CH 03/04/05 POSIZIONE DI MONTAGGIO

**B3**

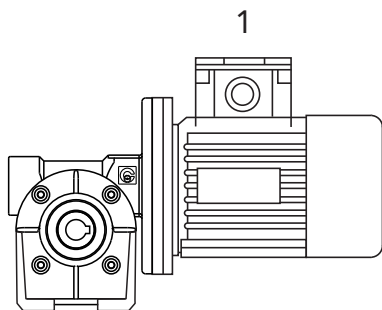

**B6**

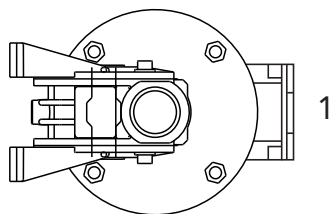

**V5**

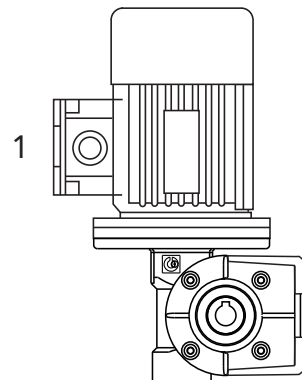

**B7**

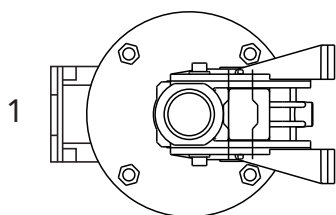

**B8**

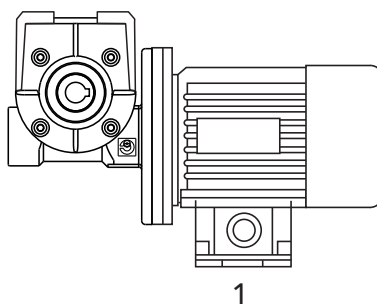

**V6**

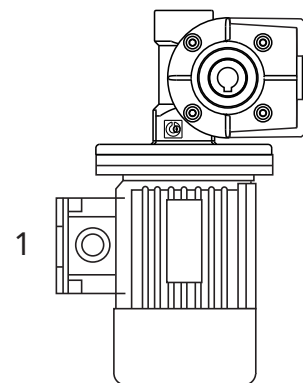

**PF1**

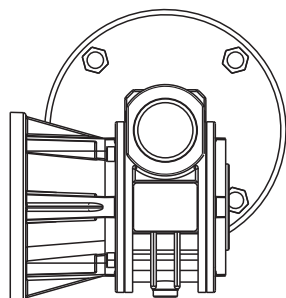

**PF2**

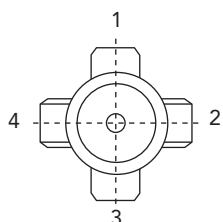
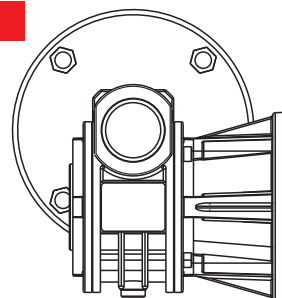

**B3**

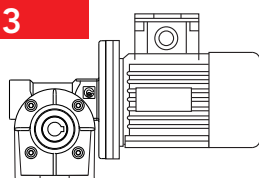

## POSIZIONE MORSETTERIA

N.B. La posizione della morsetteria si riferisce sempre alla pos. B3