

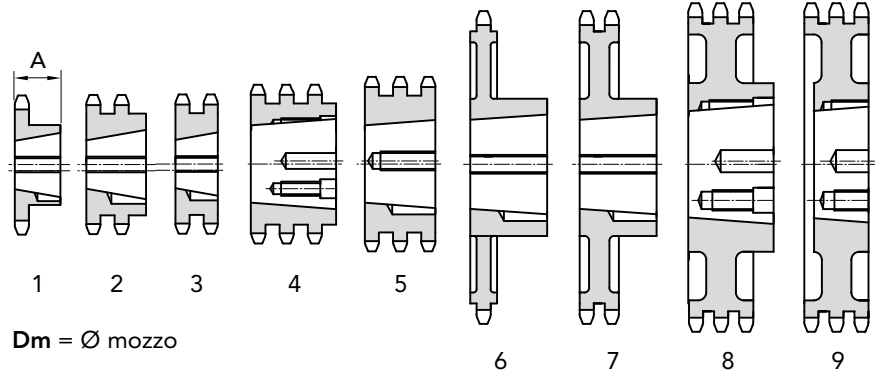

PIGNONI PER BUSSOLA CONICA TAPER LOCK®

MATERIALE ACCIAIO
C 45 UNI 5007

MATERIALE GHISA
GG20 UNI 5007



TRIPLI

Passo	CODICE	COD. PASSO	Z	per bussola	Esec. Tipo	Dm mozzo	A	Kg
3/4" 19,05 mm	17319015	061-15	15	1615	5	49,8		
	17319017	061-17	17	2012	5	49,8		
	17319019	061-19	19	2012	5	49,8		
	17319021	061-21	21	2517	5	49,8		
	17319023	061-23	23	2517	5	49,8		
	17319025	061-25	25	2517	5	49,8		
	17319027	061-27	27	3020	4	140	51	
	17319030	061-30	30	3020	4	140	51	
	17319038	061-38	38	3020	4	140	51	
	17319045	061-45	45	3020	4	140	51	
	17319057	061-57	57	3020	8	160	51	
	17319076	061-76	76	3020	8	160	51	
	17319095	061-95	95	3030	8	165	76	
	17319114	061-114	114	3030	8	165	76	
1" 25,40 mm	17325017	061-17	17	2517	5	79,6		
	17325019	061-19	19	3020	5	79,6		
	17325021	061-21	21	3020	5	79,6		
	17325023	061-23	23	3525	5	79,6		
	17325025	061-25	25	3525	5	79,6		
	17325027	061-27	27	3525	5	79,6		
	17325030	061-30	30	3525	5	79,6		
	17325038	061-38	38	3535	8	178	89	
	17325045	061-45	45	4040	8	216	102	
	17325057	061-57	57	4040	8	216	102	
	17325076	061-76	76	4040	8	216	102	
	17325095	061-95	95	4040	8	240	102	
17325114	061-114	114	4545	8	240	115		

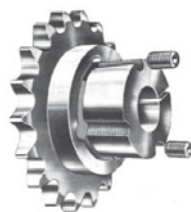

PIGNONI PER BUSSOLA CONICA TAPER LOCK®